



# Operation & Maintenance Manual

Compact 60 and Vacuum Compact 60  
Priorclaves





## Introduction

Priorclave autoclaves are a range of general-purpose laboratory autoclaves intended primarily for media preparation, the making safe of ordinary laboratory and pathological waste and other apparatus sterilisation purposes. The autoclaves are manufactured to a high standard and feature a number of patented innovative design features. The sophisticated **TACTROL** microprocessor control system provides a very simple method of setting even the most complex cycles. The machines have been designed from the outset for easy and safe operation and maintenance.

Properly looked after and serviced your autoclave should give years of valuable and trouble free service.

### Priorclave Service

**Serial Number:** \_\_\_\_\_

**Date of Manufacture:** \_\_\_\_\_

**Software Version:** \_\_\_\_\_

Please quote the above when asking for parts or service:

### **PRIORCLAVE LIMITED**

129 -131 Nathan Way  
West Thamesmead Business Park  
London  
SE28 0AB

**Telephone:** +44 (0)20-8316-6620

**Fax:** +44 (0)20-8855-0616

**E-mail:** service@priorclave.co.uk

**Website:** www.priorclave.co.uk

or your local service agent:

## Symbols used in this manual and their meanings



### **WARNING: Mechanical Hazard**

In this manual, warnings draw attention to the potential for Danger to personnel up to and including risk of severe injury or death. Each Mechanical Hazard Warning is emphasised by the icon to the left.



### **WARNING: Electrical Hazard**

In this manual, warnings draw attention to the potential for Danger to personnel up to and including risk of severe injury or death. Each Electrical Hazard Warning is emphasised by the icon to the left.



### **WARNING: Bio-hazard**

In this manual, warnings draw attention to the potential for Danger to personnel up to and including risk of severe injury or death. Each Bio-hazard Warning is emphasised by the icon to the left.



### **Caution: -Please Note**

In this manual, cautions draw attention to the potential for Damage to equipment. Each caution warning is emphasized by the icon to the left.

## Important Notices and Warnings



Priorclave Pressure Vessels and Autoclaves are manufactured according to BS2646 Part 1 (1993). It is recommended that the user/operator ensures that the autoclave is installed, operated, maintained and tested according to parts 2,3,4 & 5 of this standard for safe and effective use and that an adequate logging record of operation and maintenance be established.



Before despatch from our works all Priorclaves are subjected to rigorous electrical safety tests to the appropriate standards. Should you or your contractors carry out further insulation and flash tests as part of your internal procedures please disconnect the switch mode power supply before testing. Failure to do so will result in a test failure and may lead to corruption of the microprocessor memory which cannot be covered by our warranty.

### Safety

If you are unclear about any aspects of this manual, the use and operation of the autoclave or your autoclave process please contact Priorclave or your authorised Priorclave dealer before proceeding.



**Always wear gloves a facemask and adequate protective clothing when unloading an autoclave and ensure that the workload does not exceed safe limits.**

Priorclave are pleased provide training for operators in the use of their autoclaves at a small extra charge.

### Thermal Lock

The safety Thermal Lock (80°C door retention device) has been set in accordance with the load and procedure defined in paras. 3.3.3.2.3 and 3.3.3.3 of BS2646 Part 5:1993.

The relatively light load defined under this procedure may not be appropriate to the load to be autoclaved in your Priorclave. Therefore, to ensure compliance with Health & Safety Executive Guidance Note PM73 'Safety at Autoclaves' and to avoid possible injury you are strongly advised to have your autoclave with its normal working load formally validated, and the thermal lock set up accordingly by properly trained personnel.

### Stainless Steel Pressure Vessels.



Vessels are manufactured from grade 316 stabilised stainless steel, designed built and tested in accordance with PD5500 category 3 as required by BS2646 Part 1. Grade 316 stainless steel is employed to reduce the corrosive effects of substances such as hydroxides and chlorine. However we recommend that the interior of the vessel is kept free of such potentially harmful substances and is regularly cleaned out with soft water. The use of chlorine based or other aggressive cleaners is not recommended. Exposure to such chemicals could damage the surface finish and the integrity of the pressure vessel and door. Care should also be taken not to routinely introduce such chemicals where they are used to pre-wash items that form part of the load. In such cases the items should be thoroughly rinsed before autoclaving.

### Product Life

Due to fatigue occurring in normal use the life of all pressure vessels is finite regardless of corrosion, erosion or other damage. Using calculations from PD5500, and assuming working at the maximum working pressure of 2.4 bar this gives the autoclave vessel a projected fatigue life of 15,000 operating cycles. The lifespan of the autoclave will obviously depend upon frequency of use, but for example (based on a 365 day working year) if the autoclave is used two or four times per day this gives a working life of 20.5 to 10.2 years respectively. Your own usage of the autoclave should be considered to determine the actual lifespan of the

autoclave.

## Cleaning



This equipment contains sensitive electrical equipment. Although designed to withstand laboratory conditions it is not designed for wet cleaning. Cleaning this equipment by hosing down may cause damage, invalidating the warranty, and may cause an electrocution hazard.

External cleaning should be carried out with a damp cloth or with proprietary, non-abrasive cleaners.

## Water Supply and Quality

This autoclave has been designed to operate most effectively with a softened water supply.

Connection to a hard water supply can lead to a build up of scale and will damage the heaters and other parts of the system and could invalidate the warranty.



Equally demineralised, distilled or RO water supplies should not be used with this autoclave as the controls fitted rely on electrical conductivity to detect water levels.

RO water will damage some elements of the generator system.

## Servicing and Maintenance of Priorclave Autoclaves

Priorclave Laboratory Autoclaves are complex pressure systems designed and built to special regulations and as such should only be serviced or maintained by properly trained personnel. Priorclave Ltd. cannot be held responsible for hazards or damage resulting from work carried out on the pressure system including its closure components by untrained or unauthorised personnel. If in doubt please contact Priorclave Service or your nearest authorised service agent.

## CE Marking

The CE mark applied to this autoclave is applied in relation to the EMC (Electromagnetic Compatibility) directive and the Low Voltage directive of the European Community. This indicates that this Priorclave autoclave meets the following technical standards:

### **BSEN61000-6-3:2001**

Electromagnetic Compatibility. Generic Emission Standard. Residential, Commercial & Light Industry.

### **BSEN61000-6-1:2001**

Electromagnetic Compatibility. Generic Immunity Standard. Residential, Commercial & Light Industry.

### **BSEN61010-1:2001**

Safety Requirements for Electrical Equipment for Measurement, Control and Laboratory use.

### **BSEN61010-2-040:2005**

Safety Requirements for Electrical Equipment for Measurement, Control and Laboratory use; Part 2-041, Particular Requirements for Autoclaves using Steam for the treatment of Medical Materials and for Laboratory Processes.

## Pressure vessels

### **PD5500 2009**

Unfired fusion welded pressure vessels

### **BS2646 1996**

Autoclaves for sterilisation in laboratories

Conformity assessment modules B1 + D of the European Pressure equipment directive have been applied to ensure compliance with the essential safety requirements.

A “Declaration of Conformity” in accordance with the above standards has been made and is on file at:

**Priorclave Ltd.**  
**129 /131 Nathan Way**  
**West Thamesmead Business Park**  
**London SE28 0AB**

## Environmental Conditions

This equipment has been designed for safe operation within the following environmental conditions:

Indoor Use.

Altitude up to 2,000 M. (See Appendix B - Steam Table for special conditions affecting calibration for operation at elevated altitudes).

Temperatures between 5°C and 27°C. - The cooling performance of Air Cooled autoclaves, however will be significantly affected at higher temperatures in this range.

Maximum Relative Humidity of 85% at any temperature between 5°C and 40°C.

Mains Supply Voltage Variations not exceeding  $\pm$ 10% of that shown on the Serial Plate.

## Electromagnetic Interference

This equipment has been designed to comply with the requirements for immunity from electromagnetic interference under normal conditions of use. Care should be taken when positioning the equipment however, to avoid interference from potential extreme sources of interference such as MR scanners or x-ray equipment.

## Hazard Statement

### Electrical Hazard Stickers

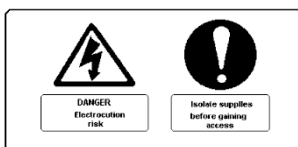

When this sticker has been placed on a removable panel the power must be switched off before the panel is removed. There may be a number of areas behind the labelled panel that constitute an electrical shock hazard. All such panels are service access panels only and should not be removed unless there is a full understanding of the equipment.

Date of issue: 30/04/2011

Revision No: 8

Place of issue: Manufacturers works

Reference: ecdec\40-60 – PED series assembly



## EU Declaration of Conformity

This is a global declaration relating to the entire pressure equipment of the product range identified below

**Equipment Manufacturer:**

Priorclave Ltd  
129-131 Nathan Way  
West Thamesmead Business Park  
London, SE28 0AB, UK

**Equipment Description:**

Priorclave Laboratory autoclaves – C40-C60 series, with Tactrol microprocessor control system.

**Model Numbers:**

PS/MID/C40, PS/MID/C60. For direct steam heated variants substitute S for E. All of the front loading units may be suffixed DBL to denote double entry versions.

**Conformity Data:**

Directive	Relevant standards	Comments	
Low Voltage Directive 72/23/EEC	EN61010-1 2001997 BS EN 61010-2-040:2005		
EMC Directive 89/36/EEC as amended by 93/68/EEC	EN50081-1 EN50082-1 EN61326 1997 (+A1/A2)	Technical construction file ref EMCTCFAU  Competent Body: Inchcape testing Ltd Manfield Park Cranleigh Surrey  Testing conducted in 2004 without certification by a competent body.	
Pressure Equipment Directive 97/23/EC Conformity assessment Modules B1+D	PD5500 2000 BS2646 1993	Notified Body No 0037  <b>Zurich Risk Services</b> Park House, Bristol Road South, Rubery B45 9AH	<u>Approval references:</u> <b>Vessel (module B1) Certificate number</b> SS42059010-5 <b>Assembly certificate number</b> SS42059010-23 <b>Interlock certificate number</b> SS42059010-25 <b>Manufacturing (module D) certificate number</b> SS42072280-01

**Declaration:**

Priorclave Ltd declares that the above products conform with the essential requirements of the above directives. Where appropriate this has been demonstrated by the application of the relevant standard(s). The CE mark was first affixed to these products in 1996

Signed for and on behalf of Priorclave Ltd

T. Collins  
Managing Director.





# Contents

- Introduction..... 5**
- Symbols used in this manual and their meanings ..... 6**
- Important Notices and Warnings ..... 7**
- EU Declaration of Conformity..... 10**
- Contents ..... 11**
- Layout Diagram..... 13**
- Operating Summary..... 15**
  - Cycle Abort and Thermal Lock Override ..... 15
- Preparing Your Priorclave for Use for the First Time ..... 16**
  - Positioning ..... 16
  - Provision of Space and Access for Accessories ..... 17
- Installation..... 18**
  - Electrical..... 18
  - Drainage and Exhaust Gas Ventilation..... 18
  - General..... 22
  - Initial Commissioning..... 23
  - Full Commissioning and Performance Qualification..... 23
- Operation ..... 25**
  - Opening the Door ..... 25
  - Loading..... 26
  - Settings..... 26
  - Automatic Timed Free-Steamng ..... 27
  - Pulsed Free-steaming ..... 28
  - Load Sensed Process Timing ..... 28
  - Rapid Cooling ..... 29
  - Media Warming ..... 29
  - Delayed Start Time..... 29
  - Vacuum Options (MVA (vacuum) models only) ..... 30
  - Multi Program Memory Options ..... 31
  - Closing the pressure door..... 32
  - Starting a cycle ..... 32
  - Vent button..... 32
  - During the process time..... 33
  - Cooling ..... 33
  - Thermal lock..... 33
  - Cycle complete..... 34
  - Media Warming ..... 34
  - Aborting a Cycle ..... 34
- Changing Date & Time..... 35**
- Operation with Options & Accessories ..... 36**
  - Setting Lock Keyswitch Option..... 36
  - Printer ..... 36
  - Serial Interface ..... 37
  - USB Interface ..... 37
  - Automatic Waterfill Option ..... 37
  - Air Intake Filter ..... 38
  - Vent Filter ..... 38
  - Internal Validation System..... 38

Heater Over-temperature Protection .....	38
Accelerated Media Cooling .....	39
Chart Recorder .....	39
<b>Warning Indicators and Fault Codes .....</b>	<b>40</b>
<b>Maintenance .....</b>	<b>42</b>
Weekly Maintenance .....	42
Monthly Maintenance .....	43
Quarterly Maintenance .....	44
General Maintenance .....	46
<b>Specification Table .....</b>	<b>49</b>
<b>Spares List .....</b>	<b>51</b>
<b>Notes .....</b>	<b>54</b>
<b>Appendix A - Fault Finding &amp; Rectification Guide .....</b>	<b>55</b>
<b>Appendix B - Steam Table .....</b>	<b>57</b>
<b>Appendix C - Wiring Diagrams .....</b>	<b>59</b>
Output Board Designations .....	59
<b>Appendix D - Pipework Schematics .....</b>	<b>63</b>
<b>Appendix E - Other Options Fitted .....</b>	<b>65</b>

# Layout Diagram



## Control Panel Details

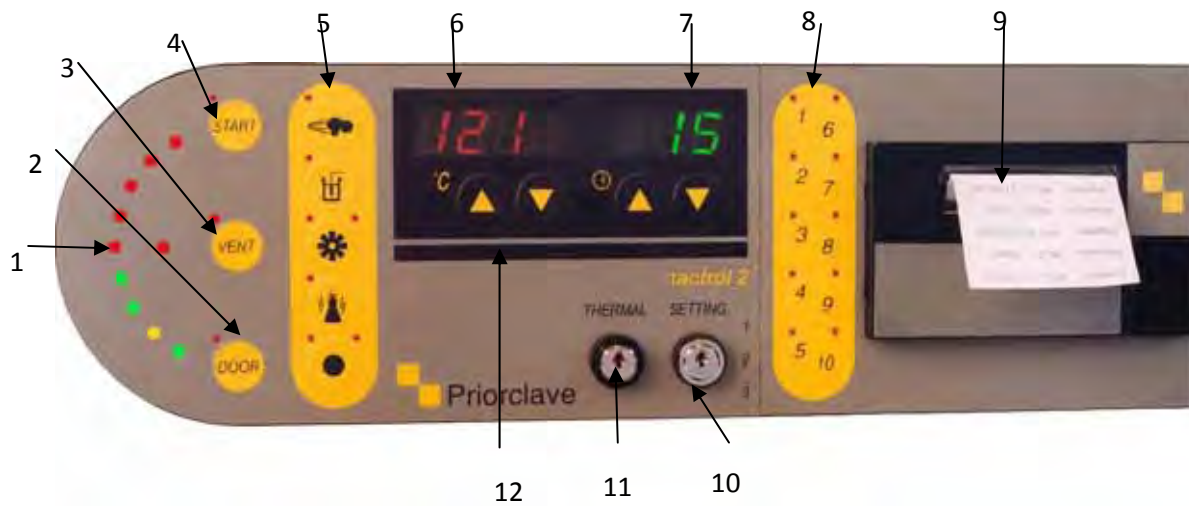

1. Cycle Progress Display
2. Door Button & Indicator
3. Vent Button & Indicator
4. Start Button & Indicator
5. [Unlabeled]
6. [Unlabeled]
7. Time Display & Setting Buttons
8. Program Buttons & Indicators (Optional)
9. Printer (Optional)
10. Setting Lock Keyswitch (Optional)
11. [Unlabeled]
12. [Unlabeled]

## Operating Summary



Before proceeding please check the specification sheet at the front of this manual to establish which options and accessories, if any, are fitted to your Priorclave. This will determine whether you will need to read the instructions for these options later in this manual or in Appendix D.



1. Check electricity supply is **ON**, and that the power switch is switched **on**.
2. Press the '**Door**' button on the control panel there will be a bleep and the message '**Hold**' will be displayed in the temperature display. Wait for a short time until the temperature display returns to normal, there is another bleep and the door indicator illuminates. The door button can now be pressed again to release the lock.



3. Move the locking handle to the right until it reaches its safety stop.

**Do not move the handle until the lock has withdrawn as this may lead to damage.**

4. Release the safety catch by pushing it down with your thumb and move the locking handle to the end of its travel. The door can now be opened.
5. Top up with water if necessary to below the load support plate in the bottom of the autoclave.
6. Load the autoclave.
7. Set the temperature as required using the up/down keys.
8. Set the process time as required using the up/down keys.
9. Set / select other functions i.e. free-steam, rapid cooling etc., as required and if fitted.
10. Carefully close the door with the locking handle fully to the right.
11. Move the locking handle to the left in one action to lock the door.
12. Wait a few seconds for the '**start**' indicator to illuminate, and press the '**start**' button to begin the cycle.

## Cycle Abort and Thermal Lock Override

### Aborting a cycle

To abort the cycle at any stage press the '**Start**' Button

### Thermal Lock Override

First abort the cycle as above.

After checking that there is no pressure within the autoclave turn the thermal lock key to the right hold it there.

Press the '**Door**' button once, keeping the thermal lock key held over.

Wait during the '**Hold**' display until there is a bleep and the '**Door**' indicator illuminates.

Keep the key held and press the '**Door**' button once to unlock the door.

The key-switch can now be released and the door opened as above.



If the key is released at any stage the procedure must be repeated to open the door and reset the display.

# Preparing Your Priorclave for Use for the First Time



Unpack the autoclave and check against the delivery note that all items ordered have been delivered.

Any shortages or damage **must** be reported to Priorclave within 7 days of delivery.

## *Positioning*

When positioning the autoclave consideration should be given to proper access for servicing and maintenance purposes. Space must also be allowed for pipe-work and electrical connections.

The autoclave has castors fitted to allow positioning and should ideally be positioned within easy reach of a suitable isolatable electrical supply and drain. (See Installation).

The autoclave should be positioned within easy reach of a suitable electrical supply and drain (if required). See Installation.

All autoclaves during their process cycle will release steam and heat, and this should be taken into consideration when choosing a site in your laboratory in which to install your autoclave

### **Maintenance access**



It is stipulated by British Standard 2646 that autoclaves should have 1 metre clear space all round to allow for service access, but we recognise that this can be difficult to provide. At minimum we would recommend a minimum of 500mm clear space all round. If it is not possible to provide this all round it may be acceptable to provide space to one side only provided the autoclave service connections can be made such that the autoclave (if size permits) can be moved without difficulty. In the case of all pipe connections provision should be made to ensure that rigid pipe work can be readily disconnected.

A space to the rear of the autoclave of up to 300mm can be required to accommodate pipe-work connections. This will reduce for more simple installations such as autoclaves without vacuum systems. For autoclaves with drain condensers this space should be increased to 500mm. The requirements for most additional items are described later.

### **Heat emission**



Regardless of insulation arrangements etc employed to reduce the temperature of the autoclave outer casing all autoclaves will emit heat into the work area. For the comfort of staff it is recommended that autoclaves are installed in air conditioned areas. Heat output from the autoclave will vary at different stages of the cycle. For the purpose of calculating loading placed on the air conditioning system by the autoclave it should be adequate to allow for a figure of one third of the total heater power of the autoclave, although the actual output will vary according to the autoclave settings used.

Air cooled autoclaves cool more quickly in a cool room, and therefore high ambient temperatures increase autoclave cycle times. This can become particularly problematic if the ambient temperature exceeds 35°C

### **Steam emission**

If correctly installed as described below, there should be no steam emitted to the work area during operation, there may however be some steam emitted when the autoclave door is opened. Under normal circumstances the thermal cooling lock will prevent the door from being opened until most of the steam in the chamber has condensed, however under certain circumstances such as the when the thermal cooling lock override is used significant amounts of steam can be released. Consideration should be given to how this steam may affect smoke

and heat detectors etc.

### **Extractor Hoods**

An extractor hood fitted above the autoclave will eliminate any remaining difficulties related to steam emission, and will also be beneficial in reducing heat build-up. Autoclaves used for processing waste materials may produce unpleasant odours, the autoclaving of waste plastic ware may also produce potentially harmful fumes, the effects of these will also be minimised by an extractor hood. An air flow rate of  $0.5\text{M}^3/\text{sec}$  is often specified for a medium sized autoclave, although this should be considered along with the hood size. It is possible to provide an output from the autoclave to boost fan speed immediately prior to door opening.

The minimum practical size of extractor hood for an autoclave is around 1 metre square. In the case of top loading autoclaves this should be positioned directly above the autoclave. In the case of front loading autoclaves the hood should extend beyond the front of the autoclave by approximately 700mm. This will be sufficient to minimise steam and fume emission into the work area, but it may also be desirable to extend the area of the hood to cover the entire autoclave to reduce the amount of heat released into the room. In the case of direct steam heated autoclaves it may also be advisable to arrange the hood or incoming steam supply in such a way as to cover the incoming steam supply pipe work and reducing valves etc. This will further assist in the elimination of heat build-up within the work area.

## ***Provision of Space and Access for Accessories***

### **Autoclaves with drain condensers**

Drain condensers are generally fitted within a side extension on the right-hand side of the autoclave panelwork and require sufficient space to be allowed for pipe-work to enter the condenser. Drain condensers may operate at high temperature depending on final settings, and effectiveness of the cooling water supply. Consideration should be given to heat hazards when deciding on the location of a condenser.

### **Autoclaves with exhaust filtration**

The location of exhaust filters will vary according to the individual specification of the autoclave.

In the case of bench mounted autoclaves it is not possible to locate the filter inside the vessel due to space constraints and limitations of currently available filter mediums. It is therefore necessary for the filter to be located in a separate pressure vessel outside of the autoclave. External exhaust filter housings are located to the upper right rear of the autoclave, and protrude from top right-hand side as viewed from the front of the autoclave by up to 200mm. In normal circumstances the filter housing will be accommodated as part of a 175mm side extension on the right-hand side of the autoclave, which may also house other bulky accessory items such as a drain condenser, water fill system or a vacuum pump. Special arrangements for the location of exhaust filters can be made on request.

It is normal for exhaust filter housing to reach temperatures in excess of  $100^{\circ}\text{C}$ , therefore consideration should be given to heat hazards when deciding on the location of an autoclave with an exhaust filter. Provision should be made to protect personnel from heat hazards whilst maintaining adequate access for filter replacement. A minimum height of 500mm is required above the top of the filter housing for replacement of the filter.



Provision should be made to guard or insulate pipes exiting the autoclave where these may present a heat hazard.

# Installation

## Electrical

### Connection to UK & EC power supplies

To connect your Priorclave to the power supply simply plug the fitted plug provided into a suitable socket. If the plug is removed the autoclave must be connected via a plug and socket or isolator rated for at least 13 Amps.



This Equipment **MUST** be earthed

Heating is by a 3kW immersion element within the autoclave's water reservoir.

The main circuit breaker is incorporated into the **ON/OFF** switch. The plug supplied with the autoclave is fused at 13A. The main processor control board is independently fused at its power supply.

See Wiring Diagram for more details.

**If a cable and plug has been fitted to the autoclave there should be no need for any further electrical installation.**

### Connection to other power supplies



For areas where a 110V single phase or 220V three phase supply is usual the autoclave can be connected across phases to operate on a 220V supply.

If not already supplied as a supplementary sheet to this manual separate instructions are available by contacting Priorclave - [service@priorclave.co.uk](mailto:service@priorclave.co.uk) – making sure to include the autoclave serial number in your correspondence.

## Drainage and Exhaust Gas Ventilation

The various inlets and outlets are situated at the back of the autoclave and are labelled with their individual functions. Within the space constraints of the autoclave cabinet, where possible drains and inlets have been combined to reduce the number of connections required. Please read the following guidance before proceeding with connection to drains and water supplies.

### General



Autoclaves used for processing laboratory waste must be provided with a drainage connection as described below. This is a requirement of British Standard 2646. A connection will also be required if the autoclave is fitted with any free-steaming or vacuum options as significant amounts of steam will be released from the autoclave at different stages of the cycle. The hazard groups below are as defined by the Advisory Committee on Dangerous pathogens as published in *Categorisation of Pathogens According to Hazard and Categories of Containment*.

**Extract from BS2646 Part 2 1990**

#### 7.2 Drainage system

*“The drainage system from the autoclave should prevent dispersion of splashes and steam into the working area. For autoclaves designed for a make-safe process, discharge should be directed to a sealed discharge system; the system should lead by direct connection to a building drain or catchment tank.*”





An open tun dish is not suitable for the discharge line of a laboratory autoclave, which is to be used for a make-safe process.

The sealed discharge system should be vented to a high level by a pipe not less than 30mm diameter. The vent pipe should be directed outside the building. Steam should not emit from the vent pipe."

**From Scope of BS2646**



"This Part of BS2646 gives guidance on the planning for, and installation in laboratories of, autoclaves for the sterilisation of materials and equipment, including those which may be contaminated with organisms categorised as Hazard Groups 1, 2 or 3. It does not cover the installation of autoclaves used for material contaminated with organisms categorised as Hazard Group 4, for which complete containment of condensate is considered to be essential."

A further comment in a later clause adds...

"In certain circumstances, e.g. special research activities involving high concentration and/or large volumes of agents in Hazard group 3, additional safeguards may be required. The advice of the Health and Safety Executive should be sought in each such case. Further containment than that detailed above, (Generally as described below in this case.) filtration or heat treatment of discharge is only necessary for autoclaves used to process material contaminated with organisms in Hazard Group 4."

**In case of any doubt the full text of BS2646 should be consulted.**



The autoclave requires a sealed connection to a trapped building drain. This drain should be provided with a heat resistant vent pipe of 30mm minimum diameter vented freely to atmosphere at a safe location outside the building. Care must be taken in the design of the drainage connection to ensure that an air break will be preserved at all times to prevent the autoclave from sucking water back from the drain as it cools. Excessive back pressure produced by restrictions in the vent pipe may impair the function of the autoclave. Note that at some stages of the cycle the autoclave may discharge steam under pressure, and if vent flow is inadequate steam may be forced to exit via other interconnected drains.

If possible it is always advisable to connect the autoclave to a drain to cut down on the amount of steam discharged into the laboratory. A compression fitting should be incorporated in the drainpipe in an easily accessible location to enable easy disconnection for maintenance purposes.



All drain piping should head downward towards the drain to prevent water collecting in the pipe.

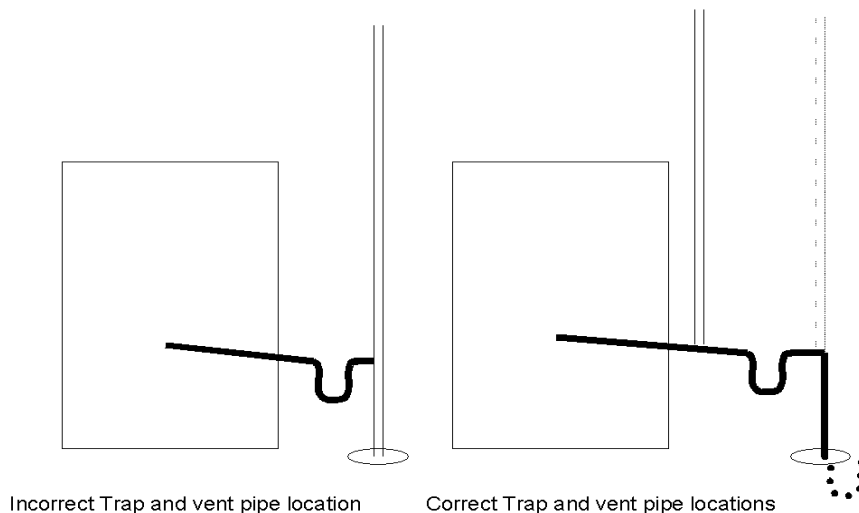



Attention should be paid to the material of the vent pipe as steam and water discharged from the autoclave can be at temperatures in excess of 100°C. In the case of autoclaves with pulsed free-steaming, vacuum drying, and vacuum cooling it may be advisable to fit a drain condenser to cool the autoclave discharge, and condense the steam.

The drain and vent pipe should be in place prior to commencement of installation by Priorclave. It will then be possible to make connections from the autoclave directly into the drainage services provided.

The point where connection from the autoclave to the drainage system is made should be within 2 metres of the autoclave. The location of individual connections is shown on the installation drawings.

### Multiple autoclaves in a single location

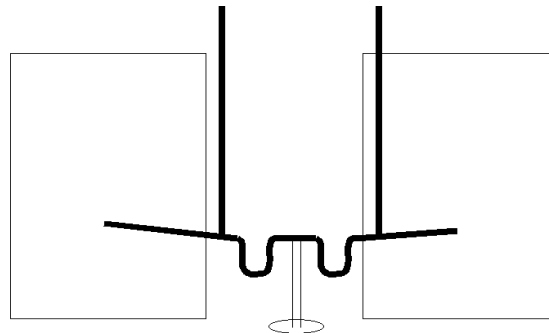

If two autoclaves share a common drain separate vent pipes and traps are required to prevent cross flow of steam and water



If more than one autoclave is to be installed at a single location then the services described need to be provided for each autoclave. If more than one autoclave is utilising the same drain and/or vent arrangement, then there may be problems due to cross flow of effluent between autoclaves. For example if one autoclave is being loaded by the operator whilst the other is in the free-steaming stage, then it may be possible for hot air and steam being discharged by one autoclave to enter the other presenting a hazard to the operator. If common services are to be shared it is essential that these are sufficiently isolated from one another to prevent cross flow.

### Safety Valve



All autoclaves are fitted with an over pressure safety valve to protect the autoclave from over pressurisation. This valve will emit large volumes of steam in the event of the autoclave exceeding its maximum working pressure. It is a requirement during safety valve function, and routine testing to be able to see and hear if the safety valve has operated.

It is Priorclave's preferred policy to direct the safety valve outlet to discharge to the floor at the rear of the autoclave, however some establishments prefer safety valve outlets to be piped to a high level outside the building.

If this is required the pipe-work for this should be provided, and terminated within 1 metre of the safety valve discharge point at the rear of the autoclave. All safety valve pipe-work should be DN25. A drainage point should be provided at the lowest point of the safety valve pipe-work. This should be a pipe of approximately 6mm ID, and should be positioned to discharge into a suitable receptacle to the rear of the autoclave. No valve should be fitted to this drainage point thereby allowing it to act as a "tell tale" indicating if the safety valve is operating.



Under no circumstances must any isolating valve be fitted to the safety valve pipe-work. External pipe-work must be designed to be self draining, and under no circumstances should water be able to collect in a trap, which could freeze in cold weather. See also BS3970 part 1

1990, sections 7.2.4 and 7.2.5.

**Autoclaves with water tanks and drip trays**

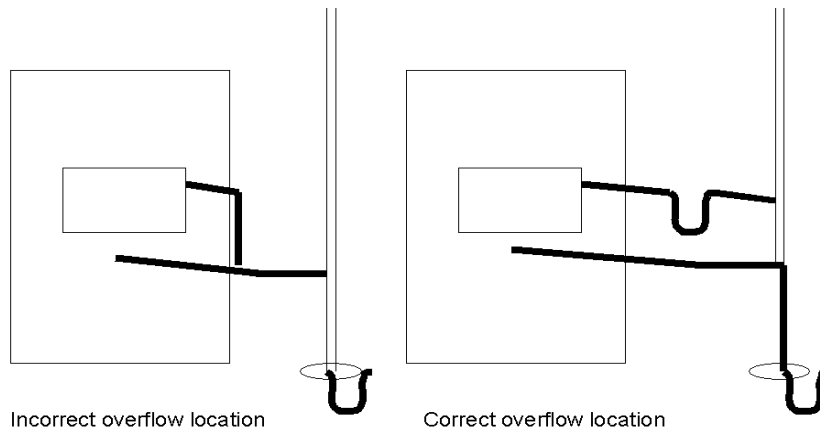

A separate drain is required for the connection of water tank and drip tray outlets. This may be a common connection to the same drainage system as above, but in such cases a sufficient level of isolation (such as a deep trap) is required to prevent the cross flow of steam between the drains. The drip tray and water tank overflow can be connected to an open tundish if desired. This has the advantage of making any discharge from the overflow visible, which is in accordance with water bylaws.

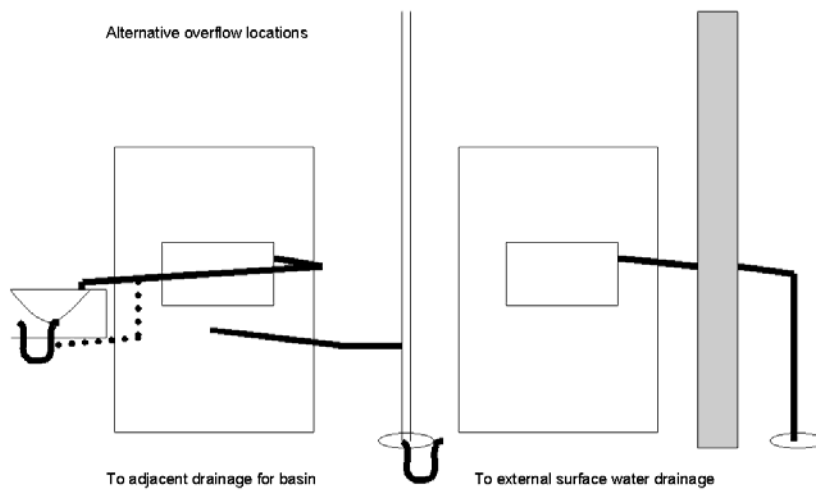

**Water Supplies and Back-flow Prevention**

***The Water Supply (Water Fittings) regulations 1999***



**Note:** The fluid categories below relate only to the above regulations, and are in no way connected with the containment categories previously discussed with reference to drainage and containment of pathogens.

It is mandatory that the completed installation complies with the Water Supply (Water Fittings) regulations 1999 – SI No 1148. This will be dependent on factors outside of the autoclave such as the layout of the water supply provided. The location and usage of the autoclave will determine the fluid category for which back-flow prevention measures are to be taken, however it is suggested in the guidance notes to the above regulations that all laboratories in industrial and commercial installations are considered category 5. Prevention measures suitable for fluids in this category may therefore need to be considered.



The back-flow prevention measures already provided within the autoclave are as follows:

***Autoclaves with Automatic Water Fill Systems and Liquid Ring Vacuum Pumps***

Water is fed to the autoclave vessel and vacuum pump via a header tank with air gap and circular overflow, which is classified type AF. This alone will provide back-flow prevention measures suitable for fluids up to category 4. Provided that the supply to the autoclave is delivered via a header tank with similar prevention means elsewhere in the building the installation will form an air gap with interposed cistern of type AUK, which is suitable for fluids up to category 5. Separate header tanks for each of these functions are provided allowing the automatic water fill tank to be fed from a treated water supply, and the vacuum pump to be fed from an untreated supply to economize on the use of treated water if required. Considerations for the use of treated water are discussed later.

### ***Autoclaves with Water Cooled Condensers and Water Jackets***

For installations falling into lower fluid categories it will be possible to use mechanical means to prevent back flow such as a verifiable single, or non-verifiable double check valve. For higher fluid categories non-mechanical means such as break tanks must be applied. Due to the pressure and flow rates required for the condensers to work effectively it is not practical to provide header tanks locally to the autoclave. The condenser and or jacket will work more effectively when more cooling water flow is achieved across the condenser, therefore the more head of water that can be provided the better.

Arrangements to meet the back-flow prevention requirements will therefore need to be made at a high level. If a water feed from a suitable header tank arrangement to satisfy the regulations cannot be provided it will be necessary to take other measure such as the provision of a break tank and pump arrangement locally to the autoclave.

## **General**

All water supplies should be terminated on the wall to the rear of the autoclave, at a point within one metre of the point of connection to the autoclave.

In hard water areas it will be necessary to use softened water for the supplies to the autoclave to prevent scaling of the autoclave vessel and heating elements. Hard water can also reduce the life span of liquid ring vacuum pumps and drain condensers when fitted, however the cost of supplying treated water to these may be considered prohibitive, and if this is the case, then a second water supply will be required. If the autoclave is to be connected to a distilled or demineralised water supply care should be taken to guard against the corrosion of copper pipe-work due to excessive purity of the water supply. The water level detection system of most autoclaves is operated on a conductivity-based system, due to this feed water requires a minimum conductivity level of 10-15 micro Seimens.



Autoclaves with an automatic water fill system require a DN15 water supply terminated in an appliance tap with a suitable connector for a standard appliance hose.

Autoclaves with liquid ring vacuum pumps require a further DN15 water supply terminated in a 1/2" BSP/DN15 compression fitting.

Autoclaves with drain condensers require a water supply for the condenser. The size of connection for this will vary depending upon the specification for the individual autoclave. In most cases a supply in DN20 will suffice, however in some cases expanding up from a DN15 supply locally in the area of the autoclave may not provide a sufficient water flow to reduce the autoclave discharge to the desired temperature.



**Consideration should be given to the discharge from the Vent and Safety Valve outlets, which should be directed in such a way as to not cause a hazard. This will be determined by the location of the autoclave.**

## ***Initial Commissioning***

Priorclave Autoclaves are given a full operational test before leaving the factory and as such arrive ready for immediate use after installation. It is advisable however to run a simple cycle with the autoclave empty before processing a working load to check that no problems have arisen during transport.

If commissioning has been ordered with the autoclave this will be carried out by a Priorclave technician otherwise follow this simple procedure to check the operation of your Priorclave.



1. Check electricity supply is **ON**, and that the power switch is switched **on**.
2. As you are powering up the autoclave for the first time the fault code **F004** will be displayed on the temperature display. You may ignore this at this stage as opening the autoclave and filling it with water will reset this error code.
3. Press the '**Door**' button on the control panel there will be a bleep and the message '**Hold**' will be displayed in the temperature display. Wait for a short time until the temperature display returns to normal, there is another bleep and the door indicator illuminates. The door button can now be pressed again to release the lock.
4. Move the locking handle to the right until it reaches its safety stop. Do not move the handle until the lock has withdrawn as this may lead to damage.
5. Release the safety catch by pushing it down with your thumb and move the locking handle to the end of its travel. The door can now be opened.
6. The autoclave uses an immersion heater in a reservoir of water at the bottom of the autoclave to raise steam. The heater is protected from boiling dry by a low water cut-out. The reservoir should be filled with water to a level below the load support plate.
7. Set the temperature to 121°C using the up/down keys.
8. Set the process time to 15 minutes using the up/down keys.
9. Set / select other functions i.e. free-steam, rapid cooling etc., as required and if fitted.
10. Carefully close the door with the locking handle fully to the right.
11. Move the locking handle to the left in one action to lock the door.
12. Wait a few seconds for the '**start**' indicator to illuminate, and press the '**start**' button to begin the cycle.
13. During the cycle, check that there are no problems during heat-up and process.

Following successful completion of the commissioning cycle your Priorclave is ready to process its first working load.

Please refer to the **Operation** section later in this manual before running your first working load as this gives further details on operation of the autoclave and on the control options which may be fitted

If you experience any problems during this procedure please contact Priorclave service or your local agent.

## ***Full Commissioning and Performance Qualification***

If you are having the unit commissioned by a Priorclave technician this will be a simple matter of checking for correct installation, checking that all functions are operating correctly, and familiarising you with the autoclave. There are, however some benefits that can be gained from having your Priorclave commissioned to suit your particular loads and requirements. Some examples of settings that can be optimised during commissioning, and the advantages

these can provide are listed below.

- Establishing optimum freesteam temperatures for effective air displacement.
- Establishing optimum freesteam time for effective air displacement, whilst eliminating unnecessary time and energy consumption.
- Establishing optimum process time and temperature to ensure complete sterilisation, whilst maintaining minimum cycle time and energy consumption.
- Setting thermal lock release temperature to suit your particular load, to eliminate unnecessary cooling time whilst ensuring safety.

If you feel that any, or all of the above would be of use to you then please contact Priorclave Service.

## Operation

**Before using your Priorclave for the first time check that the power supply is switched on.**



Before proceeding please check the specification sheet at the front of this manual to establish which options and accessories, if any, are fitted to your Priorclave. This will determine whether you will need to read the instructions for these options later in this manual.

### *Opening the Door*

1. Switch on the power at the **ON/Off** switch. All indicators will light momentarily and a sounder will bleep. This is to enable the indicators to be checked.



If you are powering up the autoclave for the first time, or if the autoclave is in a low water condition the error code **F004** will be showing in the temperature display. You may ignore this at this stage as opening the autoclave and filling it with water will reset this error code.

2. The **start** and/or **low water** indicators should now be lit. Check that the pressure gauge is reading zero and then press and release the **door** button, which will bleep, and wait for a short time (about 20 seconds) until the **door** indicator illuminates and the sounder bleeps again.
3. During the waiting time the temperature display will show **Hold**, confirming that the autoclave is waiting during its safety delay.
4. On pressing the **door** button a second time, you may hear the locking solenoid operate. You may now move the locking handle to the safety catch position. (The **vent** button will light when the **door** button is pressed and remain lit after the handle is moved)



**Do not attempt to open the door before the lock has released or damage to the locking mechanism may result which will not be covered by the warranty.**

5. The door is retained by the safety catch. In the unlikely event of undetected residual pressure being present the safety catch prevents the door from being blown open by breaking the gasket seal whilst retaining the door, thus allowing the pressure to escape safely from around the edge of the door.
6. The safety catch is released by pushing it down with your thumb and then moving the locking handle to its fully open position. The door can now be pulled open gently.



**Care should be taken when opening the door as it will be hot and steam may be released. Heatproof gloves and a face shield should always be worn when unloading autoclaves.**

7. **Checking Water Level**

The autoclave uses immersion heaters in a reservoir of water at the bottom of the autoclave to raise steam. The heaters are protected from boiling dry by a low water cut-out. If the water level falls below the sensor the autoclave shuts down, the **low water** warning indicator is lit and fault code **F004** is shown in the temperature display.



In hard water areas softened water must be used to prevent scale from forming in the autoclave. If the autoclave is manually filled then distilled water can be used but when the autoclave is new, some tap water may need to be added until the **low water** lamp is extinguished as the low water cut out is operated by the water's conductivity. A visual check of the water level is always recommended before commencing a cycle.



Great care should be taken to ensure that the un-insulated part of the low water sensor is clean (see diagram in Maintenance section) as a build up of contamination here will prevent the low water cut-out from working and could lead to heater damage.

## Loading

8. The autoclave can now be loaded with the items to be sterilised in either baskets or directly onto the autoclave shelves.



Care should be taken when loading the baskets or containers not to pack them too tightly with material. Ample room must be allowed for steam to penetrate the load properly or full sterilisation will not be achieved. When using autoclave bags these should be left open with the top of the bag rolled outwards, exposing the load to the steam inside the pressure vessel.

**Care should also be taken that the contents of bags and containers are not able to spill over into the body of the autoclave vessel. Any such spillage could block pipes and valves and will not be covered by the warranty.**



For waste loads, which may leak liquids when autoclaved, watertight discard containers are strongly recommended.



Tests have shown that the depth of un-perforated discard containers should be no greater than 180mm (7") for effective air displacement from the load. Suitable containers are available from Priorclave.

## Settings.

9. Once the autoclave has been satisfactorily loaded the controls should be set for the process cycle that you require.

If your autoclave has a setting lock fitted this must be set to **position 3** to allow the parameters to be altered.

### Sterilising Temperature & Time Settings.

The Medical Research Council has recommended the following temperatures and times as being sufficient for complete sterilisation in autoclaves:

**126°C for 10 minutes.**

**121°C for 15 minutes.**

**115°C for 30 minutes.**

These temperatures and times relate of course to load temperatures and the aim in setting a cycle should be to achieve one of the above criteria in the coldest part of the load. Some loads however are sensitive to elevated temperatures for prolonged periods, making full achievement of the above impractical. However the disinfection of such loads after a short cycle, without necessarily reaching full Sterilising Temperature, is usually sufficient for most purposes.

Should you require a more precise method then the optional **Load Sensed Process Timing** may be of assistance for certain load types. If your autoclave is fitted with this option please refer to the description later in this manual.

Since there is a time and temperature 'lag' between the temperature controller probe and the load, this should be compensated for either by increasing temperature or process time, or by including in the cycle a period of free steaming with the vent open at 100°C. This can be achieved by pressing in the **vent** button manually and releasing it manually. Alternatively, the **Automatic Free-steaming** function will perform this function automatically if the option is selected.



If you have an interest in any of the options mentioned above, which can quite easily be retro-fitted, please contact Priorclave Technical Services Department.

In conclusion, when setting up the autoclaving cycle a large safety margin should be allowed within the settings.

More precise settings can be assessed by carrying out a 'worst load' test. (See commissioning).

### Setting the process time

The process timer can be set to a time up to 999 minutes. The time required is set by simply using the time up/down buttons. The set time is displayed until the set temperature is reached, then the process time begins counting down to zero in increments of one minute.



### Setting process temperature

Pressing either the up or down button momentarily causes the current set temperature to be displayed. Subsequent use of the up/down buttons changes the set temperature. If no keys are pressed for a short time, the display returns to showing the current chamber temperature.



### Selecting other functions

The function select keys may be used to switch the Timed Free-steaming, Cooling, Media Warming Option, and optional functions such as Load Sensed Process Timing and vacuum cycles, on or off at any time other than when a cycle is running. An indicator illuminates to show that a function has been selected. If an option is not fitted (or permitted in the selected program in multi-program memory models) pressing the appropriate key will result in a visual and audible fault being signalled and the function will not be selected.

## *Automatic Timed Free-Steaming*

### What is free-steaming?



Incorporating a period of free-steaming into a cycle can improve air removal in difficult loads and/or reduce temperature lag between the load and the autoclave, reducing process time at higher temperatures. Free-steaming introduces a stage during heating up to Process Temperature, when a solenoid valve at the rear of the autoclave is opened for a pre-set time. The valve opens at a factory set temperature of just above 100°C and is held open for the time set as detailed below. During this time steam is being generated in the chamber in large volumes and this creates turbulence as it passes through the load before escaping through the valve. It is this turbulence that can assist with air removal.

### Setting the free-steam time.

If free-steaming is required this is selected by pressing the **free-steam** button. The indicator lights up to show that free-steaming is selected. The time display will now flash indicating that the freesteam time, not the process time, is currently being displayed. The freesteam time can now be set (in minutes) using the up/down buttons. If no further changes are made for a short time the display stops flashing, and reverts to showing process time. If you wish to check the freesteam time or make further changes then free-steaming should be deselected, then reselected.



**Caution should be used before setting a free-steam time longer than 15 minutes. Excessive free-steaming times can use a large amount of water, increasing the possibility of the cycle not completing due to a Low Water condition.**

### **Free-steam temperature setting**

Timed free-steaming will commence at a temperature slightly above 100°C, which has been set at the time of manufacture. If required, this temperature may be increased by qualified personnel and the turbulence caused by the escaping steam pressure can further assist with air removal. It is desirable however to connect the autoclave to a drain and vent pipe (as described Installation), as the release of pressurised steam into the laboratory should be avoided.

Performance can be improved even further by fitting the optional pulsed free-steaming system.

## ***Pulsed Free-steaming***



### **(Optional Function – included for autoclaves with vacuum cycles)**

With certain loads and in certain situations the efficiency of the free-steaming process can be improved by pulsing. When available according to program then free-steaming commences as described above but at a higher temperature (usually about 112°C). Instead of remaining open for the entire free-steaming period the vent valve shuts off at a lower temperature (usually about 107°C). The autoclave then heats up again to the temperature at which the vent valve opens again. The autoclave will continue this cycle for the time set when selecting free-steaming. This continual pulsing of steam out of the autoclave creates considerable turbulence within the autoclave, helping to draw trapped air out of the load.

If fitted, this function is program specific and is usually set up during commissioning or by request on particular programs in response to customer requests at the time of ordering.

When selected as part of the program the pulsing function replaces the standard free-steam function described above.

Setting of the free-steam time for a particular program is as described above.



**Pulsed free-steaming is not suitable for bottled liquids and should not be selected for cycles intended for these types of load.**

## ***Load Sensed Process Timing***



### **(Optional Function)**

#### **Load Sensed Process Timing Function**

If this option is fitted, the autoclave will be provided with an additional thermocouple. This is a PTFE coated stainless steel armoured probe that can be positioned in the load, ideally in the coolest part. When this option is selected, the autoclave will heat to the set chamber temperature as normal. However, when the set temperature is reached the process time will not begin to count down until the load temperature, as sensed by the additional thermocouple, reaches a temperature just below the set chamber temperature. The cycle will then proceed in the usual manner.

#### **Load Sensed Process Timing Purpose**

The use of load sensed process timing can greatly assist with the sterilisation of certain types of difficult dense loads, such as large baskets of bottle caps, pipette tips or animal feed, by

ensuring that the load reaches set temperature. The system is also very effective for bagged plastic waste loads, however as these tend to melt down around the probe, consumption of probes can be high. For this type of use load validation may prove to be more successful and economical in the long term.

### Positioning Load Sense Probe

The probe should be positioned in what is anticipated to be the slowest part of the load to heat up, for example the centre of a large densely packed load, or the largest of a group of filled bottles. This is important, as there may be large variations in temperature distribution throughout the load.

**Temperature variations can be reduced by the use of timed free steaming.**

### Load Sense Thermocouples

The load sensed process timing option utilises a thermocouple connected directly to the main processor board.

Replacement thermocouples are available from Priorclave.

**See Maintenance - for details on thermocouple replacement.**

## Rapid Cooling



A fan is fitted into the bodywork of the autoclave to direct cool air over the autoclave vessel.

If selected by using the **cooling** button, the cooling fan will switch on automatically during the cooling stage of the cycle. There are three possible settings for rapid cooling, and these operate as follows:

**Off** - No indicators lit.

**Immediate start** - The cooling fan does not operate at all during the cycle.  
Left hand indicator lit. - 1 press of the **cooling** button.  
The cooling fan starts as soon as the cooling stage is reached.

**Delayed start** - Both indicators lit- 2 presses of the **cooling** button.  
The cooling fan starts after the autoclave chamber has cooled to 100°C.  
This setting is useful when autoclaving some fluid loads, as bringing the cooling fan on at temperatures above 100°C may reduce the chamber pressure too rapidly, causing the load to boil.

**In both cases the fan will switch off automatically when the cycle has reached the complete stage.**

## Media Warming



If this highly useful feature is selected the autoclave will cool to a factory pre-set temperature of 45°C. The temperature will then cycle between approximately 45° to 55°C until the door is opened. This allows, for example, nutrient media to be held as a liquid until it is needed, especially when used along with **the delayed start function**.

## Delayed Start Time

The autoclave can be set before a cycle to start at a pre-set time.

To access these settings turn & hold the thermal lock key in the override position. Press the

time up or down keys. Release the thermal lock key. **1** is displayed on the temperature display, by default **0** will displayed on the time display. The temperature display now shows the number of a list of operating parameters, the value for the parameter is shown in the time display. Scroll through the list of available parameters using the temperature up/down keys.

After no keys are pressed for eight seconds the display returns to normal.

The function of these settings is as follows:

Temp. Display	Time Display	Function	Action
1	0-24	Delayed Start Time Hour <sup>+</sup>	Enter required Start time hour (24 hour clock)
2	0-59	Delayed Start time Minute <sup>+</sup>	Enter required Start time minute
3	0/1	Start Delay Select On/Off <sup>+</sup>	0= OFF 1= ON
<sup>+</sup> The time is set in real time, therefore the clock has to be correctly set for this to work properly. After one delayed start operation, delayed start automatically switches off, and the autoclave returns to normal operation.			

For instructions on setting the clock time and for other operator settings please refer to the section **Changing Date & Time** later in this manual.

## ***Vacuum Options (MVA (vacuum) models only)***



It is strongly recommended that to achieve optimum performance from Priorclaves fitted with vacuum options that commissioning and/or load validation tests are carried out by a trained Priorclave engineer. If no particular programs have been specified your autoclave will be factory set with the following programs:



- **Program 1:** Non vacuum Cycle
- **Program 2:** Pre-Cycle Vacuum and Vacuum Cooling
- **Program 3:** Pre-Cycle Vacuum and Vacuum Drying (if specified, otherwise as program 2)



### ***Pre-Cycle Vacuum***

The pre-cycle vacuum is selected using the function select key on the control panel. With the left-hand indicator lit the Pre-Cycle Vacuum is selected. With the Pre-Cycle Vacuum selected the vacuum pump will run at the beginning of the cycle, removing much of the air from the autoclave and load. At a pre-set level of vacuum the control system switches off the pump and the normal cycle begins.

If set at commissioning a number of vacuum stages will be performed, with heating stages in between. Pre cycle vacuum is essential when autoclaving loads containing densely packed porous material.

### ***Vacuum Cooling - Suitable for Non Media Loads Only***



If fitted along with Vacuum Drying this option must be selected for attachment to a particular program in the control software during commissioning.



A vacuum cooling cycle can be selected by means of the function select key. With the option selected the right-hand lamp will illuminate. When this option is fitted it can be run along with or separately from a Pre-Cycle Vacuum. With the option selected, at the end of the process dwell time the autoclave vent is opened and the autoclave cools to a pre-set temperature with the air-cooling fan(s) operating. When the pre-set temperature is reached the cooling

fan(s) continue to run and a partial vacuum is drawn. This has the effect of evaporating liquid on the load causing it to cool rapidly. After a pre-set time air is admitted to the vessel and this process is repeated a number of times. At the end of this stage the autoclave passes immediately to cycle complete.



**Post cycle vacuum cooling must not be selected if the load contains bottled liquids, regardless of how these are contained. All liquids in the load will be evaporated. Sealed containers of liquid will explode. Unexploded containers will be in a dangerously unstable condition when removed.**



***Drying Cycle - Suitable for Non Media Loads Only (Optional Fitting)***

This option must be selected for attachment to a particular program in the control software during commissioning.



A drying cycle can be selected by means of the function select key within a program pre-designated as a drying program. With the option selected the right-hand lamp will illuminate. When this option is fitted it can be run along with or separately from a Pre-Cycle Vacuum. With the option selected, at the end of the process dwell time the water charge is drained under pressure from the autoclave, and the autoclave cools to a pre-set temperature. When this temperature is reached a partial vacuum is drawn and heaters attached to the outside of the autoclave vessel are switched on. This has the effect of evaporating liquid on the load. After a pre-set time air is admitted to the vessel and this process is repeated a number of times. At the end of this stage the autoclave passes immediately to cycle complete.



**Post cycle drying must not be selected if the load contains bottled liquids, regardless of how these are contained. All liquids in the load will be evaporated. Sealed containers of liquid will explode. Unexploded containers will be in a dangerously unstable condition when removed.**

***Multi Program Memory Options***



When this option is fitted, five program number keys are provided to the right of the control panel, each with two indicators. The indicators on the left are for programs 1 to 5 and those on the right for programs 6 to 10. If the Priorclave has been specified with a five program memory only the first five programs will be active. As each program number is selected, the indicator illuminates and the previously selected indicator is cancelled. Pressing the select button toggles between the two program numbers shown on the button.

When the program memory option is fitted a three-position setting lock keyswitch is fitted. These setting positions allow different levels of access to settings as follows.

- Position 1.** Only the currently selected program can be run. Program settings cannot be changed.
- Position 2.** All programs can be selected and run. Program settings cannot be changed.
- Position 3.** All programs can be selected and run. Program settings can be changed freely.

**NOTE: The setting lock key can only be removed in positions 1 and 2.**

Programming of settings is the same as with the standard machine, but the required program number should be selected before setting. The settings entered can then be recalled for subsequent use by simply reselecting that program number.

## Closing the pressure door

10. When you have set up the cycle parameters, carefully close the door with the locking handle fully to the left. Then, in a single action pull the handle to the right into the locked position. The door will now be properly secured.

## Starting a cycle

11. Ensure the door is properly secured and the **start** indicator is illuminated. To start the cycle press the **start** button.

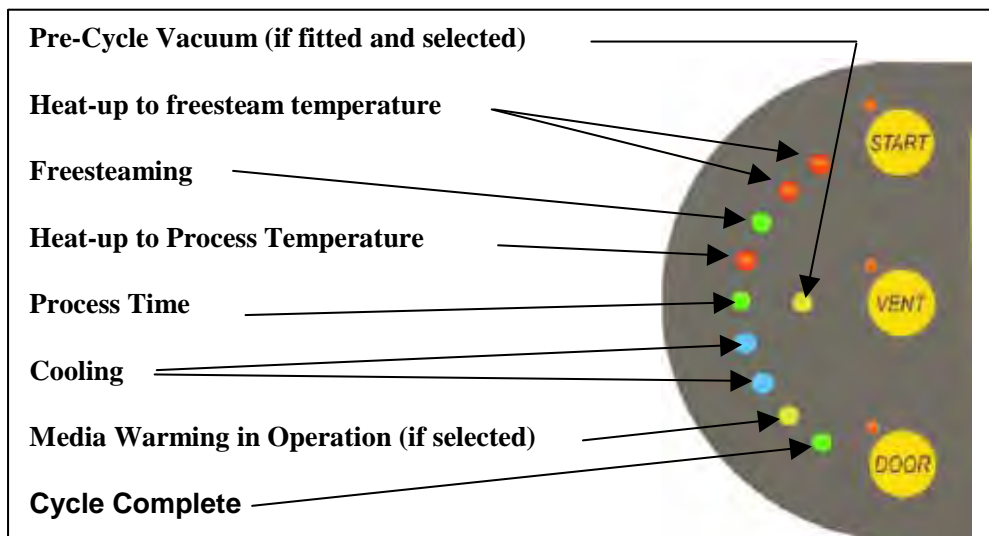

The first segment of the cycle status indicator bar will illuminate and the autoclave will now gradually heat up to process temperature. The cycle status indicator will also advance through its stages to give 'at a glance' indication of the cycle's progress.

Once a cycle has been started the function selection settings cannot be changed; attempting to do so will cause a fault to be signalled. If changes are required the cycle should be aborted by pressing the **start** button again.

Pressing the Free-steam Button  during the freesteam part of the cycle will give an indication of free steam time remaining as a flashing display in the timer window.

On Priorclaves not fitted with the setting lock key-switch changes can be made to the process time and temperature settings once a cycle has started. At the end of the cycle the time setting will reset to its original setting.

## Vent button

The **vent** button may be used at any stage during the cycle. When used it opens a large bore solenoid vent valve at the back of the machine. It may be left open for free steaming to achieve better steam penetration of the load if **Automatic Free-steaming** has not been selected. Care should be taken with this manual method however as failing to switch the **vent** off will waste a large amount of steam and to eventual cycle failure. It may also be used with certain loads as a means of rapidly venting the autoclave. If used for manual free-steaming the **vent** button must be manually released before pressure will build up and process temperature can be achieved.



**Care should be taken if using the vent button when the autoclave is pressurised. Venting of the autoclave under these circumstances with a liquid load may lead to the load boiling over and glassware may be broken.**



## ***During the process time***

12. Once set temperature is reached, the process time will begin to count down and the process indicator will illuminate. If the Load Sensed Process Timing Option is fitted and selected there may be a delay between the autoclave reaching set point and commencement of the process time whilst the load reaches set temperature.

During the process time a check should be made that there is correct correlation between temperature and pressure readings on the control panel. A steam table is included at the back of this manual for this purpose. The check should be made to ensure that air has been properly purged from the autoclave. Generally, a pressure reading higher than would be expected will indicate entrapped air in the autoclave.

If for any reason the temperature is forced outside of a pre-set band, or power to the autoclave is removed during the process time, the cycle will abort and the fault indicator will illuminate and a fault code of either **F005** or **F006** will be shown in the temperature indicator. This is to ensure that loads that have not been subjected to the required cycle parameters are not assumed to have been processed correctly. The fault condition is cancelled by:

**If no setting lock keyswitch is fitted:**

pressing the reset button on the top right hand side of the back of the control box,

or

**If a setting lock is fitted:**

turning the setting lock key to the enable position and then to the disable position. If the lock was in the enable condition when the fault occurred, then it must first be turned to the disable position.

## ***Cooling***

13. After completion of the process time the autoclave moves into the cooling part of its cycle, and this is shown on the cycle status indicator in blue. If **Cooling** has been selected this will be switched on automatically according to the cooling strategy selected. Otherwise cooling will be by convection.

If there is a power fail while the autoclave is in the cooling part of the process the cycle will resume in the cooling phase once power is restored.

If the power should fail before sterilisation is complete then the cycle will be stopped.

## ***Thermal lock***

14. Under normal circumstances the autoclave cannot be opened until the temperature of the load simulator probe, which has a cooling rate assimilated to a bottle of fluid, has fallen below 80°C at which point the yellow bar on the cycle status indicator will illuminate. The temperature shown by the temperature indicator will be significantly below 80°C as this measures the temperature in the open chamber space. Pressing the door button before the thermal lock has released causes a fault to be signalled. The temperature at which the thermal lock operates is factory set. This can be reset but must only be done following commissioning by qualified personnel. The thermal lock can be overridden using the key-switch on the control panel. The keys for this switch are provided in this manual.



**Overriding the thermal lock will cause the main vent to open. Great care should be exercised when using the key-switch since liquid loads could boil over if vented at elevated pressures.**

There are circumstances, however when quicker access to the load is required. When this is necessary, first abort the cycle by pressing the start button. Then turn the key into its

horizontal position and holding it in this position, press the **door** button and wait while the **Hold** message is displayed until the **door** lamp illuminates. Finally press the **door** button to release the door lock. The thermal lock key can now be released. If the key is released before this stage then the **Hold** display will not reset and the autoclave cannot be opened. To reset the display, repeat the above procedure and open the autoclave.



**Great care should be exercised when using the Thermal Lock Override, especially with liquid loads. Even at temperatures below 100°C a liquid load in sealable glass containers will not be safe. For the above reasons only responsible personnel should keep the Thermal Lock Override key in a safe place away from the autoclave.**



**Under certain cycle abort or failure conditions the thermal safety lock can latch in the locked condition. This is because the control system will always go to the safest condition if there is any uncertainty about the cycle end circumstances. To overcome this simply go through the door open or close procedure using the thermal lock override key. Operation will return to normal as soon as the next cycle is completed satisfactorily**

### ***Cycle complete***

15. When cooling to the 'thermal lock deactivation temperature' is complete, the **complete** indicator will illuminate, and the autoclave will emit a bleep for a short time (about 10 seconds). If the Cooling System is selected it will automatically switch off at this point. The autoclave is now ready to open and unload.

### ***Media Warming***

16. If this has been selected, the autoclave will remain at the pre-set temperature after the cycle is complete, until the door is opened or the cycle otherwise aborted.
17. Opening the autoclave to unload and re-load for the next cycle is simply a repetition of steps 1 & 2.

### ***Aborting a Cycle***

On occasions it may be necessary to abort a cycle before its completion. In order to do this, simply press the **start** button.



## Changing Date & Time

A number of additional control system settings can be accessed via a “Hidden Menu”.

To access these settings turn & hold the thermal lock key in the override position. Press the time up or down keys. Release the thermal lock key. **1** is displayed on the temperature display, by default **0** will displayed on the time display. The temperature display now shows the number of a list of operating parameters, the value for the parameter is shown in the time display. Scroll through the list of available parameters using the temperature up/down keys.

After no keys are pressed for eight seconds the display returns to normal.

The function of these settings is as follows:

	Temp. Display	Time Display	Function	Action
			The autoclave can be set for the cycle to start after a pre-programmed delay, for example to allow a media preparation cycle to complete shortly prior to the start of the working day. Setting the value of parameter 1 to 1 in the time display switches delayed start on.	
	1	0-24	Delayed Start Time Hour <sup>+</sup>	Enter required Start time hour (24 hour clock)
	2	0-59	Delayed Start time Minute <sup>+</sup>	Enter required Start time minute
	3	0/1	Start Delay Select On/Off <sup>+</sup>	1= ON 0= OFF
*	4	0-999	Print Interval	Enter time (minutes)between printing during process time (0= printer disabled)
	5		Year Setting	Enter Year
	6		Month Setting	Enter Month
	7		Date Setting	Enter Day of month
	8		Hour Setting	Enter Hour (24 Hr Clock)
	9		Minute Setting	Enter Minute
	10		Second Setting	Enter Second.
			<b>Scroll back up to parameter 1 to confirm the new or current time settings.</b>	
#	11	1-999	Cycle Repeats	Enter Number of Cycles Required
<sup>+</sup>	The time is set in real time, therefore the clock has to be correctly set for this to work properly. After one delayed start operation, delayed start automatically switches off, and the autoclave returns to normal operation.			
#	<b>Models fitted with optional Cycle Repeat Facility only</b>			
*	<b>Models fitted with 5 or 10 Program Memory</b> <b>Setting marked * are program number related, and therefore should you wish to use different values for these in different programs this can be done by changing the value when the correct program is selected.</b>			

## Operation with Options & Accessories

The following descriptions detail how to operate and gain maximum benefit from the options and accessories that may be fitted to your Priorclave.

### ***Setting Lock Keyswitch Option***

Fitted on Priorclaves without program memory to give an optional level of security this keyswitch has two settings only, which are equivalent to positions 1 & 3 described previously. The key can only be removed in position 1.

### ***Printer***

The printer if fitted is mounted on the right hand side of the control panel. This provides a useful record of the cycle as well as an indication if any faults have occurred. The information printed is as follows:

USER NAME (if provided at time of ordering)  
DEPARTMENT (if provided at time of ordering)  
AUTOCLAVE SERIAL NUMBER  
DATE  
CYCLE NUMBER  
PROGRAM NUMBER (if multi-program memory option fitted)  
TEMPERATURE AND TIME AT CYCLE START (time is set to G.M.T)  
TEMPERATURE AND TIME AT END OF FREESTEAMING  
TEMPERATURE AND TIME AT START OF PROCESS TIME

The temperature and time are then recorded at pre-set time intervals, until the end of the process time.

TEMPERATURE AND TIME AT END OF PROCESS TIME  
TEMPERATURE AND TIME AT CYCLE COMPLETE.  
CYCLE PASS/FAIL/ABORT

(Fail means that a fault signal has occurred during the cycle or that the cycle was aborted. See - Warning Indicators)

The above information will be printed in the order listed, allowing the information to be read as it is printed.

### **Power On Self Test**

The self test procedure is initiated by applying power to the printer while the paper feed button is depressed. When the paper feed button is released a test print will be produced.

### **Replacing Paper Roll**

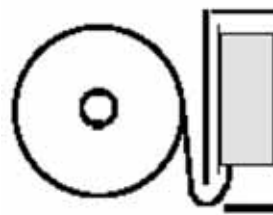
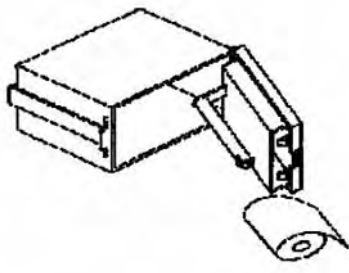

**Correct Paper Path**

Access to the printer for changing the paper roll is provided by a hinged front panel. The

spring-loaded catch on the left-hand side of the printer front panel should be depressed to release the front panel.

The paper roll carrier is mounted on the rear of the printer front panel and will swing out from the main body for ease of roll changing.



**Use the correct paper. Suitable paper is available from Priorclave Service or your local distributor.**

### Changing Printer Ribbon

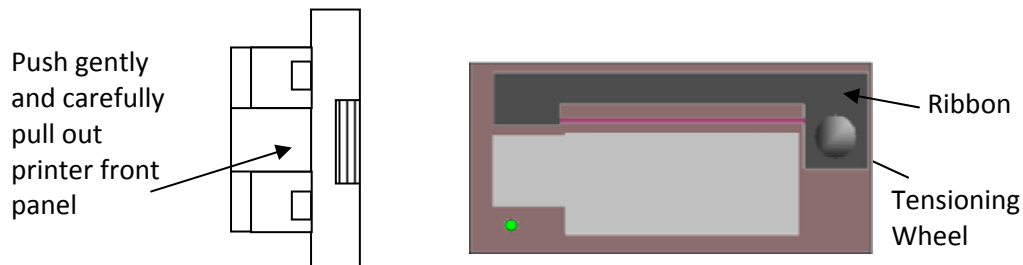

**Ribbon fitting detail**

With the door of the printer open gently squeeze the plastic cover inside the printer door at the points shown in the diagram. The outer door cover should come away (some gentle twisting may be required) exposing the print ribbon mounting plate as shown above.

The old print ribbon can be lifted out and a new one put in its place. If necessary take up any slack on the ribbon with the tensioning wheel.

The paper should pass between the ribbon and the bottom of the ribbon cassette.

The two parts of the door can now be pushed together and will click into position.

## ***Serial Interface***

The autoclave is supplied with an externally mounted serial connector and a suitable connecting cable for serial or USB connection to a computer. Also supplied is a website address from which to download the latest software and a full operation manual for the system.

## ***USB Interface***

The autoclave is supplied with an externally mounted USB port. Also supplied is a website address from which to download the latest software and a full operation manual for the system.

## ***Automatic Waterfill Option***

This option consists of a water tank mounted at the back of the autoclave and a second water level probe set to detect water level at the optimum fill level for the autoclave chamber.

The water tank is fitted with a float valve to automatically control fill level.

Whilst the autoclave door is open during loading and unloading a valve is opened and water flows into the autoclave vessel from the water tank until the upper water level probe is reached.

This system is additionally fitted with a timer that automatically shuts off the water supply after a pre-set time. This is fitted as a measure to prevent flooding in case of a failure of the water level probe.

If the timer times out before the water level reaches the probe then Fault **F016** will be displayed.

To start filling again reset the fault (see Warning Indicators and Fault Codes). The water level probe should be regularly checked and cleaned (see Maintenance Section for details)

**During normal operation only small amounts of water will need to be replaced, however when first filling the autoclave or whilst filling after cleaning, more time will be required.**

## ***Air Intake Filter***

**(Optional or fitted as part of a vacuum drying system)**

When fitted to the autoclave this system ensures that air drawn into the autoclave during the cooling stage of the cycle is first passed through a bacteriological air filter. This filter is fitted at the back of the autoclave.



The filter should be regularly changed to maintain its effectiveness

## ***Vent Filter***



When fitted to the autoclave this system passes all autoclave discharge through a filter fitted inside a pressurisable stainless steel housing. At the end of the cycle any unfiltered condensate from the filter housing is returned to the autoclave. The correct operation and effectiveness of the filter system should be regularly checked. Please refer to the manufacturer's instructions enclosed with this manual.

## ***Internal Validation System***

If fitted this system continuously monitors the performance of the temperature reading and control system with reference to an internal reference standard. If any problem is detected with the system the autoclave is stopped and a fault is signalled. (See Warning Indicators and Fault Codes for details.)

## ***Heater Over-temperature Protection***

**(Fitted as an optional extra in addition to the standard microprocessor based overheat function)**

This device acts as secondary protection against the autoclave boiling dry and damaging the heating elements in the event of failure of the low water sensing system. Should the heater elements ever exceed a temperature of 150°C the heating circuit will be switched off and the the fault code of **F018** will be shown in the temperature display.



Should this occur, then the autoclave should be switched off and allowed to cool to a safe temperature and pressure before opening for examination of the water level.

The fault indication can be cancelled as described in the Faults section. To re-run the autoclave it should be sufficient to top up with water to the correct level. However the low water system should be checked for faults as soon as possible and cleaned or repaired as necessary. (See Maintenance section.)

The overheat is activated by a thermocouple mounted on one of the heating elements inside the autoclave. This is coupled directly to the main processor board, and the overheat temperature is factory set.

## ***Accelerated Media Cooling***

Unless specified otherwise before delivery of the autoclave or set up during the commissioning process the Media cooling function is set to operate by default with **program 1**.

It can easily be re-set to operate on different programs by a Priorclave Engineer or your local approved Priorclave representative.

When selected the autoclave will carry out a standard media cycle and will begin cooling as normal with the cooling fan coming on at the end of the process time.

As the autoclave cools below 100°C the pressure on the gauge will gradually drop below 0 and into a vacuum. This assists greatly in the cooling of liquid loads giving savings of around 50% of the total cooling time to cycle completion at a safe thermal lock temperature.

Once the cycle has completed any vacuum in the autoclave is automatically released and the door can be opened in the normal way.

**For best results over sized bottles should be used, ie 500ml volumes in a 1000ml bottle.**



**Delayed start cooling (both lights lit on the cooling button) may be required if excessive media volume losses during cooling are observed.**

## ***Chart Recorder***

If fitted, the recorder power input is connected directly to the autoclave in such a way that the recorder will only operate during the autoclave cycle, i.e. from the pressing of the start button to cycle complete. At this time power to the recorder is cut. Unless otherwise specified, single channel units record the temperature of a fixed thermocouple probe, and in the case of two channel units the second channel records the temperature of the load probe.

For more details on individual recorder function and operation please refer to the manufacturer's manual supplied with the autoclave.

# Warning Indicators and Fault Codes

On the control panel there are a series of 'hidden until active' warning indicators. Some of these indicators will appear in conjunction with a fault code in the temperature display. The meaning of these warnings, why they appear, and what to do when they appear, is as follows.

## SERVICE

This means that 500 cycles, or six months have passed since the autoclave was last serviced. The engineer will cancel the message when the autoclave is serviced.

## WATER + FAULT CODE F004

The water level has fallen below the minimum level and must be topped up before the autoclave can be run. The warning will automatically cancel when the door is opened and the water level is topped up. The low water condition may have caused a running cycle to abort, and the load may need to be autoclaved again.

## O/HEAT + FAULT CODE F003

If fitted, the heater over-temperature protection thermocouple may have sensed that the heating element became too hot. This is probably due to a low water condition, which was not sensed by the low water probe. The water level and the condition of the probe (see Maintenance) should be checked before attempting to use the autoclave again.

If heater over protection is not fitted then the over-heat cut out will only operate under extreme conditions, such as a failure of the temperature control system. The next attempt to run the autoclave should be closely observed and if problems persist contact Priorclave Service.

## FAULT + FAULT CODES F000, F002, F005, F006, F007, F008, F009, F010 & F011

The fault indicator illuminates under conditions that may invalidate the autoclaving process, and may result in the load requiring to be autoclaved again. The fault condition will be triggered by any of the following:

- F006** Power to the autoclave being interrupted when a cycle is in the heating or process dwell stage of the cycle.
- F005** The chamber temperature falling below the set temperature by more than 3°C during the process dwell time.
- F002** Failure of the temperature control, display, or load simulator thermocouple.
- F000** If your autoclave is fitted with the optional self-validation system, an error in the temperature measurement system is signalled by fault code **F000**. Usually this would mean that a critical error has developed in the temperature measurement system, however, as the detection system is extremely sensitive it is possible that it may be triggered by fluctuations in the electrical power supply. If fault code **F000** appears it may be cleared by the method described below. If the fault code will not clear, or continues to re-appear then the user cannot correct the fault. In such a case please contact Priorclave service or your local Priorclave approved service agent.
- F007** Vacuum stage timeout (loop break). The autoclave has not achieved the pre-set level of vacuum during the Pre-cycle vacuum stage during the pre-set time.
- F008** Heating stage timeout. The autoclave has not reached process temperature within the Pre-set time.
- F009** Vacuum cooling set-point not achieved. The autoclave has not achieved a low enough level of vacuum during the post cycle vacuum stage (Vacuum Cooling or Drying Cycle)

- F010** Air detector input activated. If fitted the air detector system has detected an over pressure condition symptomatic of excess air remaining in the load.
- F011** Printer Timeout / Malfunction. The control system has not received confirmation from the printer within its pre-set timeout.
- F012** Door micro-switch fault. If a door micro-switch opens during a cycle this fault code is displayed
- F013** Jacket Timeout -If a jacket is fitted it has not reached the required temperature within the Pre-set time. This would indicate a problem with steam supply or inlet or drain valve operation
- F014** Jacket Over temperature - If a jacket is fitted the temperature has exceeded the pre-set alarm temperature
- F015** Jacket under temperature - If a jacket is fitted the temperature has fallen below the pre-set operating temperature band.
- F016** Water Fill Timeout - The upper level water probe level has not been reached within the allowed time for filling and the filling operation has been stopped. This function prevents continuous unsupervised operation of the water fill, which could lead to flooding.
- F017** Free-Steam - During Pulsed Free-steaming operation the lower of the two set temperatures has not been achieved. The temperature has not fallen sufficiently following the opening of the vent valve.
- F018** Heater Overheat. If this fault occurs then the most likely cause is a Low Water condition. Check the water supply is turned on and the condition of the heater before resetting this fault.

## **LOCK**

This warning will light when the thermal lock keyswitch is in the override position.

## **LOAD + FAULT CODE F001**

This warning is activated in the event of the failure of the load sensing thermocouple. The thermocouple should be replaced as soon as possible. Great care should be taken to ensure that loads which would ordinarily be autoclaved with load sensed process timing are adequately sterilised.

## **CANCELLING FAULT MESSAGES**

The fault messages are cancelled by first correcting the source of the original fault, then turning the setting lock key switch to position 3. If a key-switch is not fitted they are cancelled by pressing the reset button.

If 2 or more faults occur at the same time, the one with the highest priority is displayed. (F000 is the highest priority and F012 is the lowest.) If a higher priority fault is cleared it will be replaced by the next active fault, unless this too is cleared by the same action.

## Maintenance



Before carrying out any maintenance work check the autoclave for any visual signs of materials which may be contaminated or damaged. Should any such matter be apparent contact the relevant person of authority before proceeding.

\* Do not carry out any work unless you are competent to do so.



Items in this section marked with \* are those which require a level of competence as incorrect maintenance or fitting could lead to a safety hazard.



**Disconnect** or **Isolate** the machine from mains power supply before removing any panels or commencing any maintenance work.

Ensure that any electrically locked doors are open before disconnecting power.



In the event of any difficulty or doubt about any maintenance or service procedure contact Priorclave Limited or your nearest Priorclave approved agent or supplier immediately.

## Weekly Maintenance

### Low Water Probe

To ensure protection from boiling dry the probe sensor tip should be scrubbed clean to ensure good contact.

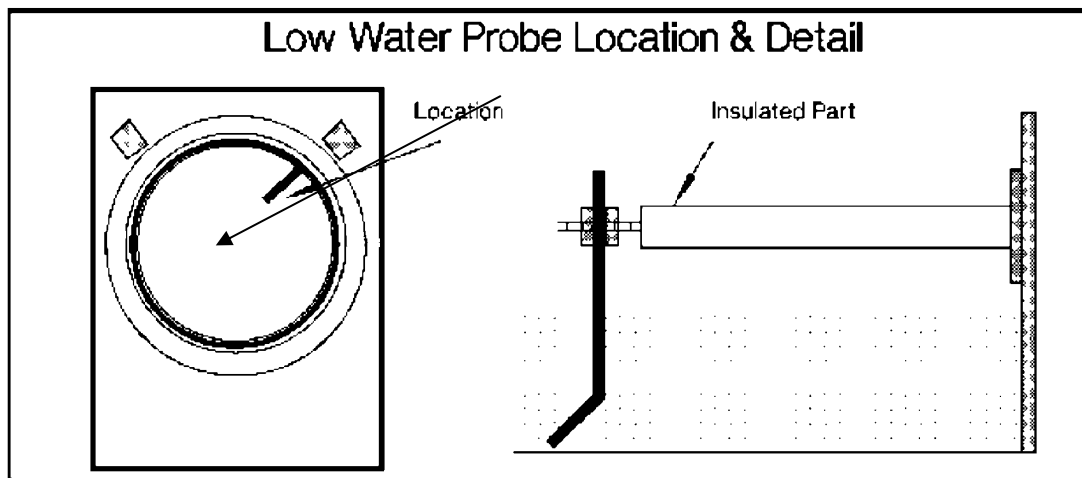

On models fitted with the automatic water filling option there are two probes of this pattern fitted inside the autoclave.

### Vessel Water Charge

The standing water within the vessel should be regularly removed, ideally with a wet/dry type vacuum cleaner to prevent the build up of spilled media and potentially corrosive chemicals. With the vessel empty the heating element(s) should be cleaned with a damp cloth to remove any build up of limescale.



If destruct type loads are regularly being processed consideration should be given to the use of suitable containers for such loads to minimise spillage. A range of such containers suitable for individual Priorclave models is available from Priorclave.



## Vessel Cleaning

Check exterior of machine and the inside walls of the pressure vessel for general cleanliness, particularly around operating parts and switchgear. Under no circumstances should an abrasive or chemically aggressive cleaner be used on the pressure vessel. The use of chlorine or hydroxide based cleaners is not recommended (see notices at the beginning of this manual).

### Gasket

To prolong the life of the sealing gasket it is advisable to lubricate the sealing faces. This is carried out with the pressure door in the open position by applying high melting point grease to the exposed surfaces of the gasket, after cleaning the gasket and inspecting for damage. A silicone grease such as high vacuum grease is ideal for this purpose.



**Although the design and material of Priorclave Gaskets makes them extremely durable and long-lasting it is advisable to regularly inspect the condition of the gasket and to change the gasket at the first sign of damage or wear and, if applicable, after 3 years of use.**

### Locking Arms

To ensure a free action of the locking arms they should be kept free from dirt and lightly lubricated with high melting point grease.

### Safety Valve \*

The safety valve should be periodically checked for freedom of movement. This can be accessed by removing the side panel on the right-hand side of the autoclave. When the autoclave is at working pressure, keeping well clear of the safety valve outlet, lift the hand lever and check for a free flow of steam from the outlet pipe. If steam does not flow the valve should be replaced or serviced by a **qualified** person immediately. After releasing the lever ensure that the steam flow stops fully.

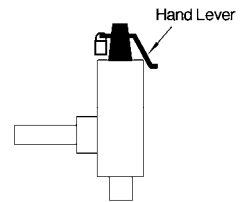

**When removing panels take care not to damage the earth leads fitted to them and always replace these leads when replacing the panels.**



### Drainage

If the autoclave has been plumbed directly into a drain using flexible tubing, this should be checked for any signs of blockage, obstruction or damage. Also ensure that both ends of the tube are connected as originally intended. Check for any obstruction to the safety valve outlet, which must remain exposed and unconnected to any form of drainage at all times.

If no external drainage is being used and the condensate is simply being collected in a tundish or other vessel at the rear of the machine, this should be emptied, cleaned and replaced.

### Door & Hinge Bolt Fixings \*

Due to the effects of constant heating and cooling it is advisable to check the tightness of the fixing bolts which retain the door in its outer cover and the hinges which fix the door to the main body of the autoclave. Tighten the door holder screws if necessary with a hexagon socket key. The hinges are held in place by nuts located at the back of the top panel. These must not be over-tightened. Ideally a torque wrench should be used set to 10 lbf. ft.

## Monthly Maintenance

To be carried out in addition to weekly maintenance programme.

### General Operation

The general operation and performance of the autoclave should be observed frequently, and any fault or defect reported or rectified immediately, and entered into the notes section of the operating manual.

### **Automatic Waterfill (If Fitted)**

The condition of the float valve tank and its various connections should be periodically checked and cleaned if necessary. Particular attention should be paid to ensuring that there are no restrictions to the tank overflow. In hard water areas the function of any anti-scaling device fitted to the water supply should be tested and the heating elements checked for signs of scaling.

In addition the condition of the water level probe should be checked as described under weekly maintenance.

### **Vacuum Pump (MVA (vacuum) models only)**

The operation of the vacuum pump should be checked regularly. Please refer to enclosed vacuum pump manual for further details.

## ***Quarterly Maintenance***

### **Hinge \***

With the pressure door in the open position the hinge should be cleaned and lightly lubricated with high melting point grease.

### **Automatic Air Purge Valve \***



**On some models the Automatic Air purge Function has been superseded by programmed automatic use of the vent valve during autoclave heat-up.**

**In these cases there will be no automatic air purge valve fitted to the autoclave and this paragraph can be ignored.**

It is advisable to replace the expanding switching element and other sealing parts contained in this unit on a regular basis, in order to prevent build up of foreign matter which may impair the operation of the unit. The valve is situated at the back of the autoclave just below the Top Panel.

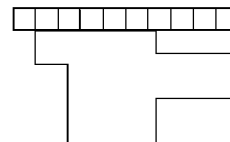

To remove the parts for replacement simply unscrew the top cap of the unit and remove. Re-assemble the unit as per the instructions in the repair kit (available from Priorclave Limited or your local agent). Should the top cap prove particularly tight the complete valve should be removed from the pressure vessel and the body gripped in a vice to remove the cap, as excessive localised pressure could damage the pressure vessel and/or its pipe-work. Care should be taken when refitting the valve to the pressure vessel that all gaskets etc., are replaced in the correct position and the unit should be checked for leaks when first re-pressurised.

### **Microswitches \***



Before working on the microswitches please ensure that the power is turned off.

To ensure the reliable operation of the autoclave the two internal micro-switches, one located behind the lower door clamp and the other below behind the locking solenoid, (behind the upper locking clamp) should be regularly cleaned and checked.

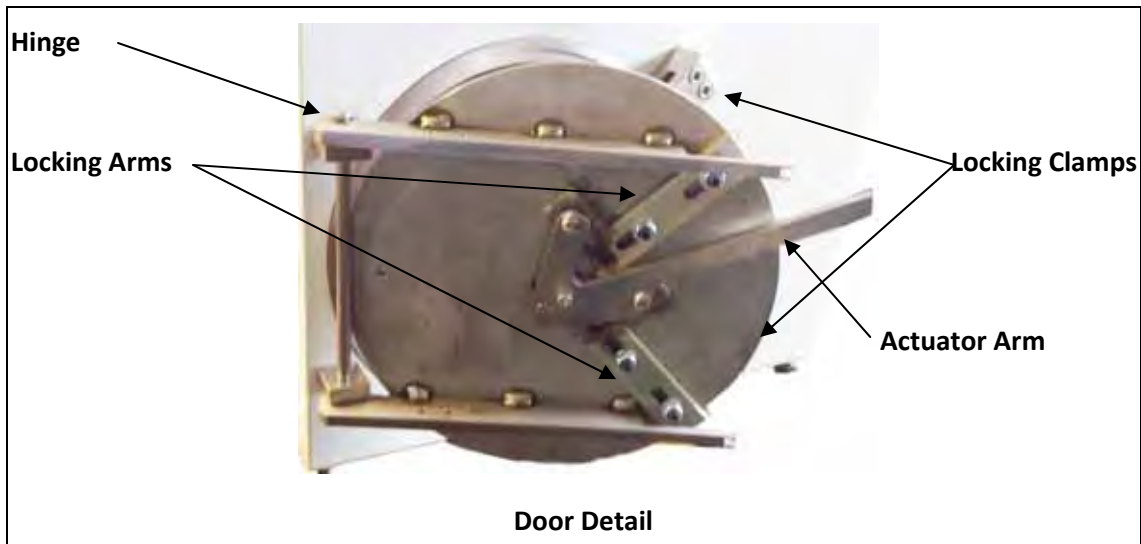

To gain access to these switches remove the right-hand side panel.



**When removing panels take care not to damage the earth leads fitted to them and always replace these leads when replacing the panels.**



The lower – Door Closed – Micro-switch is operated by an actuator pin which itself is operated by the door locking arm as it locks into the locking clamp.

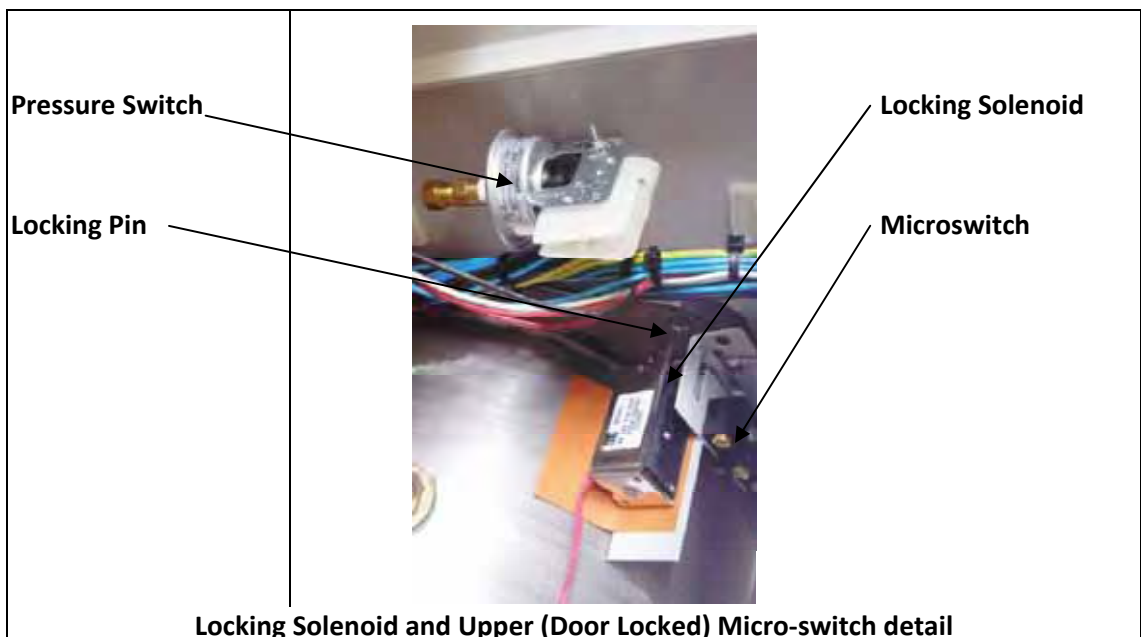

The pin should be checked for freedom of movement and the alignment and adjustment of

the micro-switch should be checked.



**Great care must be taken when adjusting the door microswitches. Incorrect adjustment could leave the autoclave in a dangerous condition. It is strongly recommended that this work is carried out only by trained personnel.**

#### Locking Solenoid \*

With the right-hand side panel removed, check the solenoid locking bolt for freedom of movement.

The upper – Door Locked – Micro-switch is operated by the solenoid locking pin which locks into a recess in the upper locking arm to lock the door.

The alignment and adjustment of the micro-switch should be checked.

#### Filters (If fitted)

The condition of air intake filters should be inspected regularly. These filters should be sterilised (they can be autoclaved) on a regular basis.



\* Outlet filters, where fitted should be regularly inspected, sterilised and replaced.

**Inadequate maintenance could cause a significant biohazard.** Please refer to the enclosed manual for the filter system for more details.

### General Maintenance



#### Removing Side Panels \*

#### Access to Control Components \*

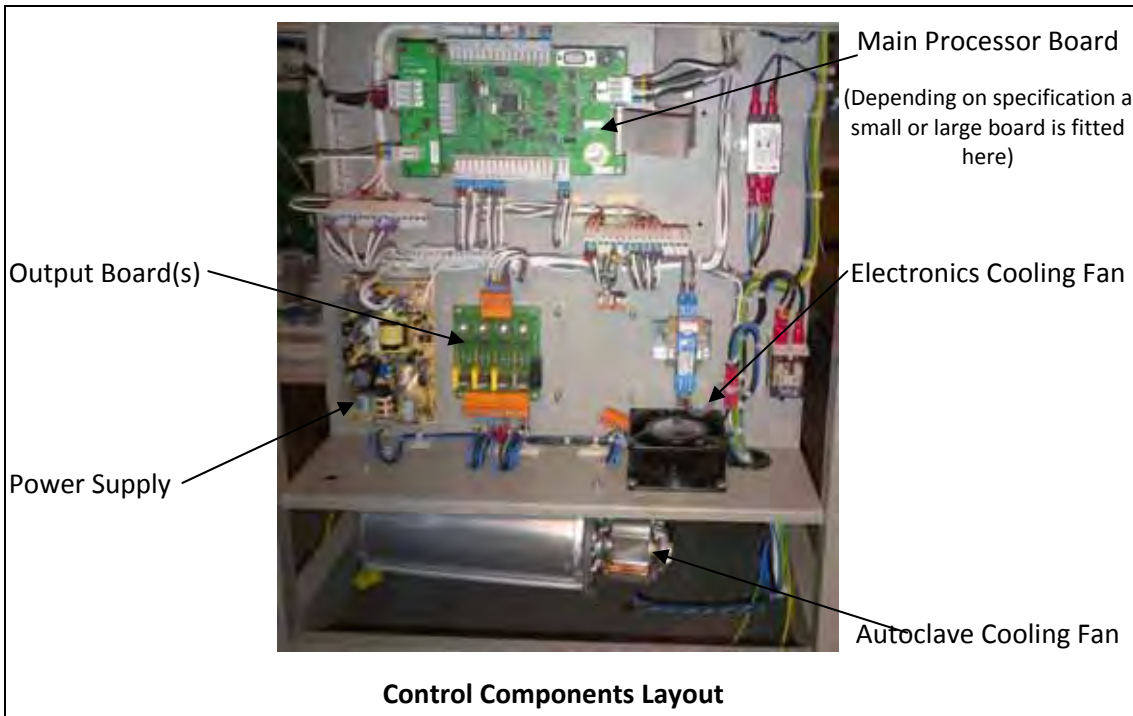

To access the control components remove the two screws at the base of the front panel and gently pull it forwards, allowing it to drop down at the top.



**When removing panels take care not to damage the earth leads fitted to them and always replace these leads when replacing the panels.**

**Ensure that the electrical supply has been disconnected before removing the front cover.**



**Although the majority of components are low voltage the power supply will be at mains voltage and is an electrical shock hazard.**

**Checking Temperature Control and Pressure Gauge \***

Should a constant deviation from the values shown in the steam table (appendix B) be apparent in these instruments first follow the relevant procedures in the fault-finding table (appendix A). With all of these possible causes eliminated, proceed to check the gauges as follows:

First, place a thermocouple probe connected to a digital thermometer or chart recorder of known accuracy onto the Temperature Controller Probe. Then set the machine and run through a standard cycle. When the process time has commenced check the reading shown by the temperature display against that of the thermometer or recorder. Should there be a disparity of readings in the order of that previously noted then it is likely that the Temperature Controller is at fault and needs resetting.

If only negligible temperature disparity is apparent, however, and the steam pressure is still varying from the expected value by the amount noted previously, then the pressure gauge is probably faulty and in need of replacement.



**The pressure gauge and control system fitted to Priorclaves are extremely reliable instruments and as such are unlikely to produce false readings. Therefore it is more likely that any deviation from the values given in the steam table is caused by incorrect air purging etc.**

**Fitting a new Door Seal Gasket\***

When it becomes necessary to replace the gasket, simply remove the old gasket by pulling it out of the groove in the pressure door.

Using an abrasive pad clean out the groove and wipe away any residue with a cloth. Locate the joint in the new gasket and press this part of the gasket firmly into the part of the groove closest to the hinge, marked A on the diagram.

Find the opposite centre line of the gasket and press firmly into the point marked B on the diagram, ensure that there is an even amount of gasket each side of points A and B. Press the gasket into the points marked C, again ensuring that there is an even amount of gasket between all 4 points.

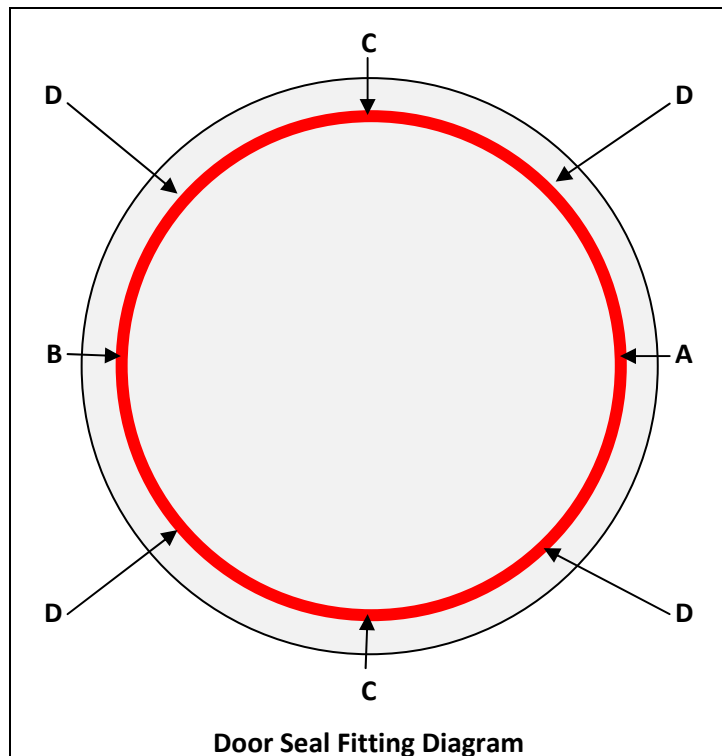

Press the gasket into the four points marked D. Finally press in the remaining points taking care not to cut the gasket on the header ring. Once the gasket is fully fitted smear the top surfaces with high temperature silicone grease if required, and smooth out any lumps, applying pressure in a circular motion around the gasket.

With the new gasket properly fitted, locking the door may at first be a little tight. Please note however that the gasket will bed down considerably when the autoclave is first used.



**Great care should be taken when fitting a door seal gasket as if this is carried out incorrectly it can affect the door sealing and ease of operation. It is strongly recommended that this work is carried out only by trained personnel.**

### Fitting a New Wandering Thermocouple

The autoclave is fitted with two thermocouple entry ports located behind the large patch panel on the right-hand side of the autoclave. The large port is intended for multiple test probes for use during Performance Qualification and the smaller port is intended for use with the wandering thermocouple used for Load Sensed Process Timing. To remove the old thermocouple first unplug it from its connection to the main control board and then undo and remove the compression nut from the fitting (see diagram).

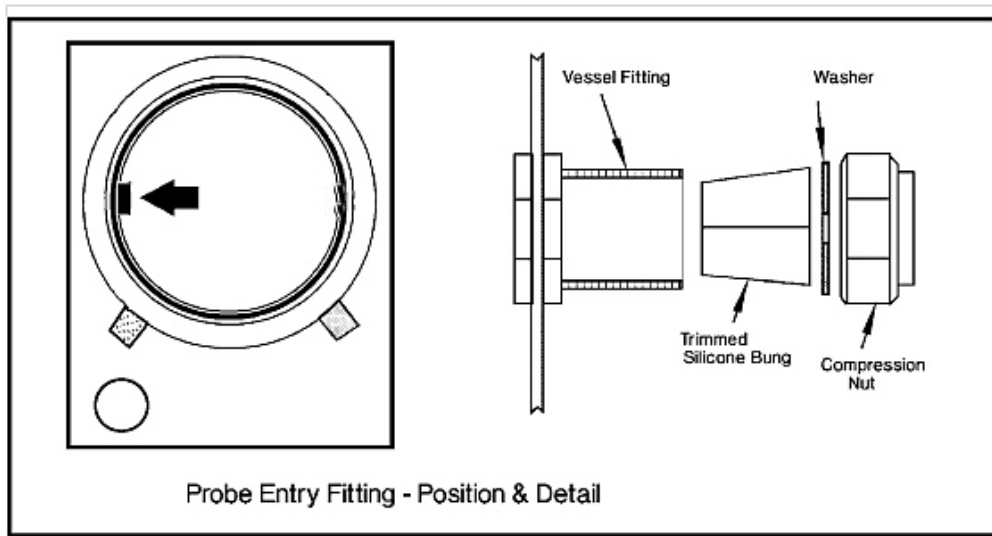

Using a suitable blunt instrument, from the inside of the pressure vessel push out the silicone rubber bung from the fitting, and remove it from the thermocouple. Next, insert the new thermocouple, it may be necessary to re-slit the bung to do this. Place the nut washer and bung in position on the new thermocouple and re-fit. It is advisable to apply some silicone sealant (such as bath sealant) to the joint to assist sealing. The joint should be checked for leaks when the autoclave is first pressurised. Replacement bungs are available from Priorclave, or alternatively use a No. 21 (large port) or a No. 13 (small port) silicone rubber bung and trim the top end by about 5mm.

## Specification Table

### Model PS/MID/C60

General	Model	Compact 60 Priorclave
	<b>Capacity</b>	60 Litres
<b>Dimensions</b>	<b>Machine (wxdxh)</b>	472x620x900mm
	<b>Installation Area Required (wxd)</b>	472x670x900mm
	<b>Extra Height for door when opened</b>	495mm
<b>Weight</b>	<b>Unloaded</b>	100kG
	<b>With water charge</b>	110kG
	<b>Door</b>	20kG
	<b>Pressure Vessel</b>	15kG
<b>Electrical</b>	<b>Power Supply Required</b>	230V 50Hz 13A
<b>Steam</b>	<b>Steam Supply Required</b>	Not Applicable
<b>Water Supply</b>	<b>Water Supply Required</b>	Softened Water – Hand Fill
		With Auto-waterfill: 15mm BSP
<b>Drainage</b>	<b>Main Drain Connection</b>	15mm BSP
	<b>Secondary Drain Connections</b>	15mm BSP (if Applicable)
<b>Max. Sound Level (working environment)</b>	<b>Without Vacuum Pump</b>	Approx. 30db @ 1M
	<b>With Vacuum Pump</b>	Approx. 75db @ 1M
<b>Max. Heat Emission</b>	<b>Full Cycle</b>	$((3h \times 1.5p) \times 0.75) / t$ kW/Hour
		Where: <b>h</b> = heat-up time (hrs) <b>p</b> = process time (hrs) <b>t</b> = Total cycle* (hrs) * to thermal lock temperature

## Model PS/MVA/C60

General	Model	Compact 60 Vacuum Priorclave
	<b>Capacity</b>	60 Litres
<b>Dimensions</b>	<b>Machine (wxdxh)</b>	472x790x900mm
	<b>Installation Area Required (wxdxh)</b>	472x875x900mm
	<b>Extra Height for door when opened</b>	495mm
<b>Weight</b>	<b>Unloaded</b>	105kG
	<b>With water charge</b>	115kG
	<b>Door</b>	20kG
	<b>Pressure Vessel</b>	15kG
<b>Electrical</b>	<b>Power Supply Required</b>	230V 50Hz 13A
<b>Steam</b>	<b>Steam Supply Required</b>	Not Applicable
<b>Water Supply</b>	<b>Water Supply Required</b>	Softened Water – Hand Fill
		With Auto-waterfill: 15mm BSP
<b>Drainage</b>	<b>Main Drain Connection</b>	15mm BSP
	<b>Secondary Drain Connections</b>	15mm BSP (if Applicable)
<b>Max. Sound Level (working environment)</b>	<b>Without Vacuum Pump</b>	Approx. 30db @ 1M
	<b>With Vacuum Pump</b>	Approx. 75db @ 1M
<b>Max. Heat Emission</b>	<b>Full Cycle</b>	$((3h \times 1.5p) \times 0.75) / t$ kW/Hour
		Where: <b>h</b> = heat-up time (hrs) <b>p</b> = process time (hrs) <b>t</b> = Total cycle* (hrs) * to thermal lock temperature



















## Spares List

A full selection of spares are available from Priorclave Service or your local Priorclave dealer. Please give your autoclave serial number when ordering parts.

A selection of the more commonly used parts is listed below:

Description	Part Number	
Air Intake Filter	<b>AFL/ACS/SML</b>	
Air Purge Valve (Complete)	<b>VPC/ACS/001</b>	
Air Purge Valve Element	<b>VPE/ACS/002</b>	
Control (Duplex) Thermocouple	<b>PRB/ACS/003</b>	
Door Gasket	<b>GAS/MID/350</b>	
Door Lock Microswitch	<b>MSA/CAN/VER</b>	
Door Locking Solenoid	<b>SOL/MID/001</b>	
Heater	<b>HTR/MID/C40</b>	

Heater Power Relay	<b>RLY/MID/HTR</b>	
Input Voltage Filter	<b>INL/ACS/FIL</b>	
Instrument Fan	<b>FAN/ACS/080</b>	
Large Cable Port Bung	<b>SBG/ACS/022</b>	
Low Water Probe Electrode	<b>LWP/RSC/000</b>	
Output Card	<b>TAC/OPT/001</b>	
Pressure Guage 63mm	<b>PSG/GAU/063</b>	
Pressure Switch	<b>PSS/SWI/001</b>	
Printer Paper Roll	<b>ZZZ/ROL/005</b>	
Printer Ribbon Cassette	<b>ZZZ/RIB/002</b>	

Safety Valve – Complete	<b>VSC/ACS/015</b>	
Setting Lock Keyswitch	<b>KEY/SLK/001</b>	
Small Cable Port Bung	<b>SBG/ACS/015</b>	
Solenoid Valve 15mm (½")	<b>VVC/ACS/015</b>	
Thermal Cut Out	<b>HCO/ACS/150</b>	
Thermal Lock Keyswitch	<b>KEY/TLK/002</b>	
Wandering Thermocouple Probe	<b>PRB/ACS/004</b>	

## Notes

## Appendix A - Fault Finding & Rectification Guide

Symptom	Possible Cause	Possible Solution
<b>No Power</b>	Power switched off at isolator	Check
	Circuit Breaker (Door Switch) Tripped	Reset and check cause
	Electrical Failure	Call Engineer
<b>Cycle does not commence when start button is pressed (Fault indicator flashes)</b>	Door is not closed properly	Open & Re-close.
	Micro-switch Failure	Check Micro-switches
<b>Heating slow or not apparent</b>	Controller incorrectly set	Check setting & reset if necessary
	Circuit Breaker (Door Switch) Tripped out	Check Circuit Breaker position. Check cause of trip & reset if necessary.
	Heater Failed	Check & Replace as necessary. Check Low Water Probes.
	Heater Over-furred	Check & replace as necessary.
	Water Reservoir overfilled	Check Water Level. Remove water if necessary.
	Fault in control circuit.	Check all connections, output board function & thermal cut-out(s).
	Fault in control circuit.	Check all connections & thermal cut-out(s).
<b>Low Water Indicator (F004) stays lit when correct water level is achieved</b>	Low Water Conductivity i.e. Distilled water	Add Tap Water
	Probe dirty, damaged or removed	Visually check probe. Clean/Replace as necessary
	Wiring connections loose or damaged	Check connections to probe and main control board.
<b>Autoclave does not pressurise</b>	Vent button in open position	Check Vent Indicator
	Freesteam time not completed (if option is selected)	Check Cycle Progress Indicator Display
	Air purge valve failure	Check and replace internal parts or valve.
	Vent Valve stuck open	Check & Replace if necessary
	Safety Valve stuck open	Check for obstructions on lifting handle.
	Door incorrectly closed	Check door position and door micro-switch settings

Symptom	Possible Cause	Possible Solution
<b>Incorrect Temperature/Pressure Correlation</b>	Air not fully purged from autoclave. Due to :	
	Incorrect Load Packing	Re-Load and re-start cycle with (more) freesteaming.
	Faulty Air Purge Valve	Check & Replace if necessary
	Water covering Controller Probe	Check Water Level
	Faulty Controller or Gauge	Check function and calibration
<b>Safety Valve opening</b>	Temperature set too high	Check Temperature Setting
	Heater Relay Failure	Check & Replace if necessary.
	Safety Valve Faulty	Check the seal on the valve is intact and has not been tampered with and that the lifting handle is not obstructed. Check the pressure shown on the gauge is above 2.4 Bar. If not replace the valve
	Output board Failure	Check & Replace if necessary
<b>Door will not open once Autoclave has cooled to 80°C</b>	Thermal Lock Temperature not yet reached in Load Simulator	<b>WAIT.</b> Thermal Lock is set to Load and not Chamber temperature.
<b>Door does not open when door button is pressed</b>	Safety delay not completed	Wait while <b>'Hold'</b> is displayed in the temperature display
	Thermal Lock Temperature not yet reached in load simulator	Check Cycle Complete indicator is lit on cycle progress display.
	Faulty Door Lock Solenoid	Check Solenoid and Output Board Function. Replace if necessary.
	Thermal Lock previously overridden	Use thermal lock key to open door. Normal function will return after a complete cycle has been run.
<b>Fault Indication will not go out</b>	Fault not Re-set. (Refer to manual for list of Fault Codes)	Rectify cause of fault and reset with Key-switch or re-set button.



**Autoclaves are pressure equipment and as such are potentially extremely hazardous if not correctly serviced.**

**If you have any doubts or If you do not feel competent to carry out any of the above procedures then do not hesitate to call Priorclave Service on 020 8316 6620 or your nearest Priorclave approved service agent.**

This device may be fitted with a non-resettable thermal cut out to protect the heater. In the event of failure of this device contact Priorclave Service or your local authorised service agent.

## Appendix B - Steam Table

### Autoclave

Temperature		Pressure (BarG)
(°C)	(°F)	
100	212	0.00
105	221	0.20
110	230	0.43
115	239	0.69
120	248	0.99
121	250	1.06
122	252	1.13
124	255	1.25
126	259	1.35
128	262	1.55
130	266	1.70
132	270	1.86
134	273	2.04
136	277	2.21
138	281	2.40
140	284	2.60

Correct Correlation between Temperature and Pressure shows correct operation of the autoclave and that air purging is satisfactory.



This table is accurate at sea level and at moderate altitudes will be sufficiently accurate for its intended purpose. However, at higher altitudes the pressures indicated will be slightly higher than those shown above.





## Appendix C - Wiring Diagrams



The following Circuit Diagrams show the wiring configuration for the standard models and in addition for the more popular options and accessories.

For Options and Accessories not covered by these standard drawings supplementary drawing sheets will be issued and these should be included within the manual and/or are available from Priorclave. (info@priorclave.co.uk)

### *Output Board Designations*

#### Output Board 1

IN		OUT	FUNCTION
	<b>1</b>		
	<b>2</b>		
	<b>3</b>		
	<b>4</b>		

#### Output Board 2

IN		OUT	FUNCTION
	<b>1</b>		
	<b>2</b>		
	<b>3</b>		
	<b>4</b>		



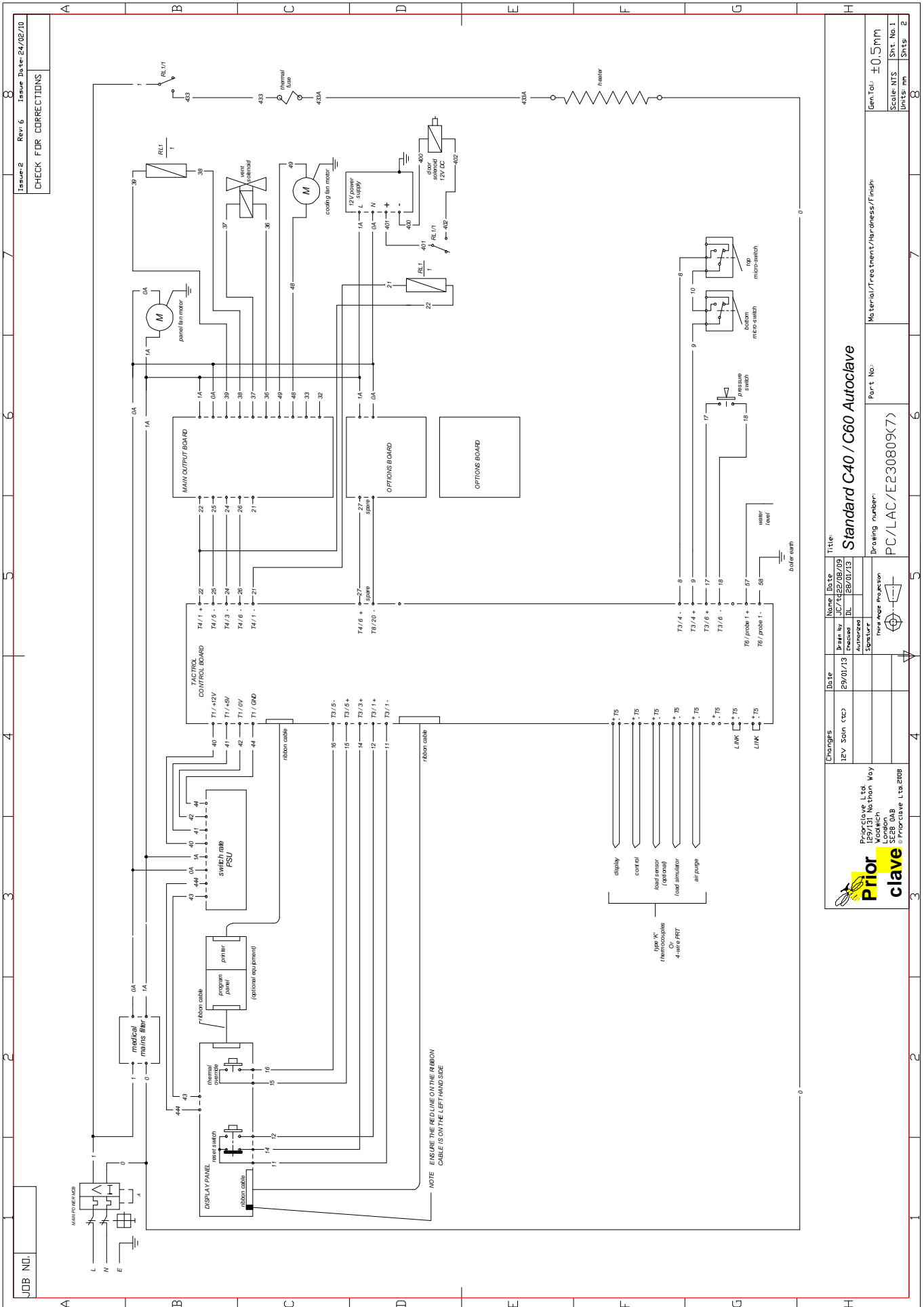

Issue: 2	Rev: 6	Issue Date: 24/02/10
CHECK FOR CORRECTIONS		

Gen Tol: ± 0.5mm
Scale: NTS
Units: mm
Sheet: 2

Material/Treatment/Hardness/Finish
Part No.
Drinking number:
PC/LAC/E230809(7)

Changes	Date	Name	Date	Title
1EV Soln (cc)	29/01/13	JULIUS	29/01/09	
		DR	28/07/13	

**Prior**  
 Priorclave Ltd.  
 1000 Northway  
 London  
 E16 1JH  
 © Priorclave Ltd 2008

Drawn by: J.ULIUS	Checked by: J.ULIUS	Approved by: J.ULIUS
Standard: J.ULIUS	Standard: J.ULIUS	Standard: J.ULIUS
Project: J.ULIUS	Project: J.ULIUS	Project: J.ULIUS

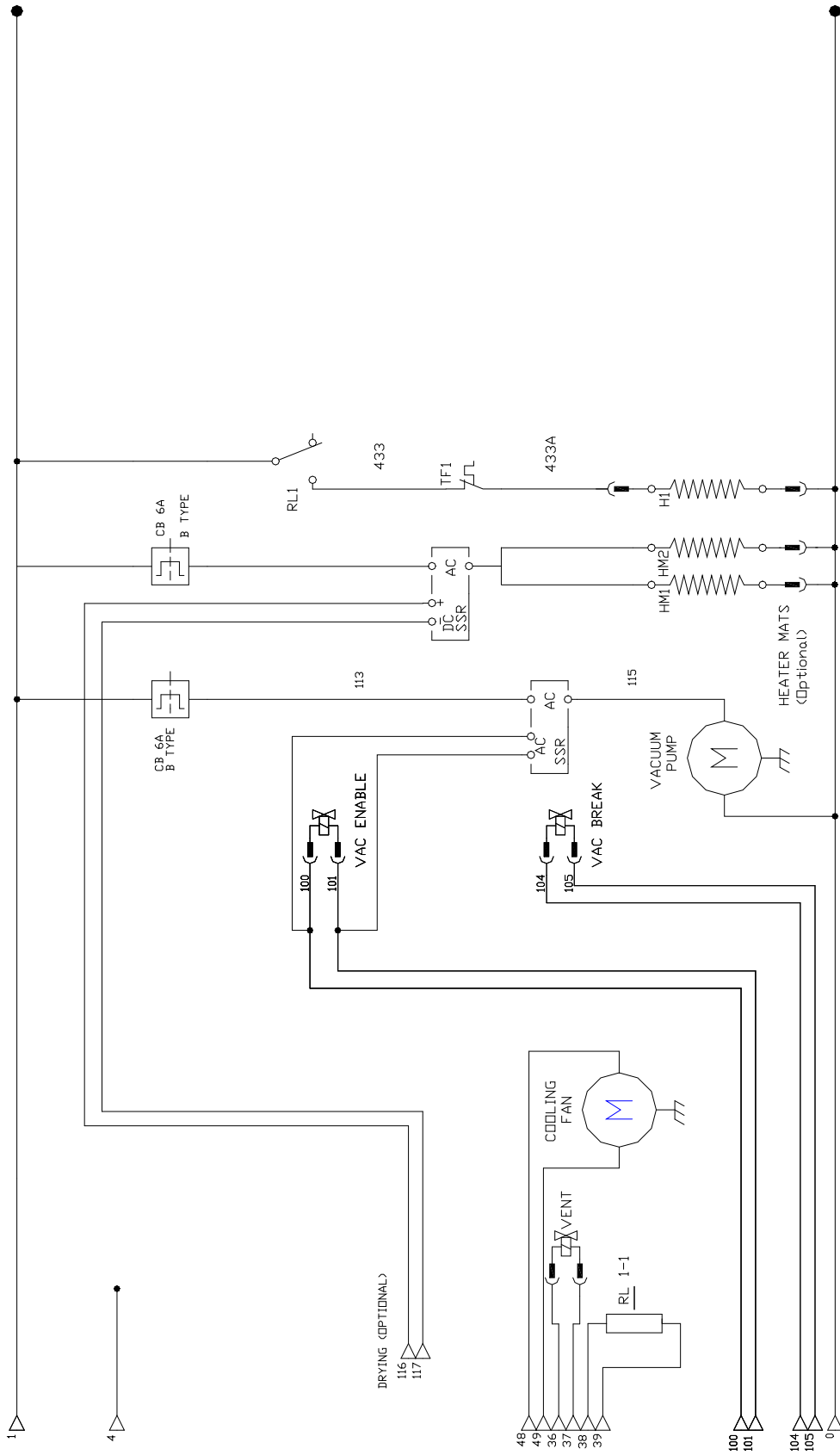

# Appendix D - Pipework Schematics



The following Pipework Schematics show the wiring configuration for the standard models and in addition for the more popular options and accessories.

For Options and Accessories not covered by these standard drawings supplementary drawing sheets will be issued and these should be included within the manual and/or are available from Priorclave. (info@priorclave.co.uk)

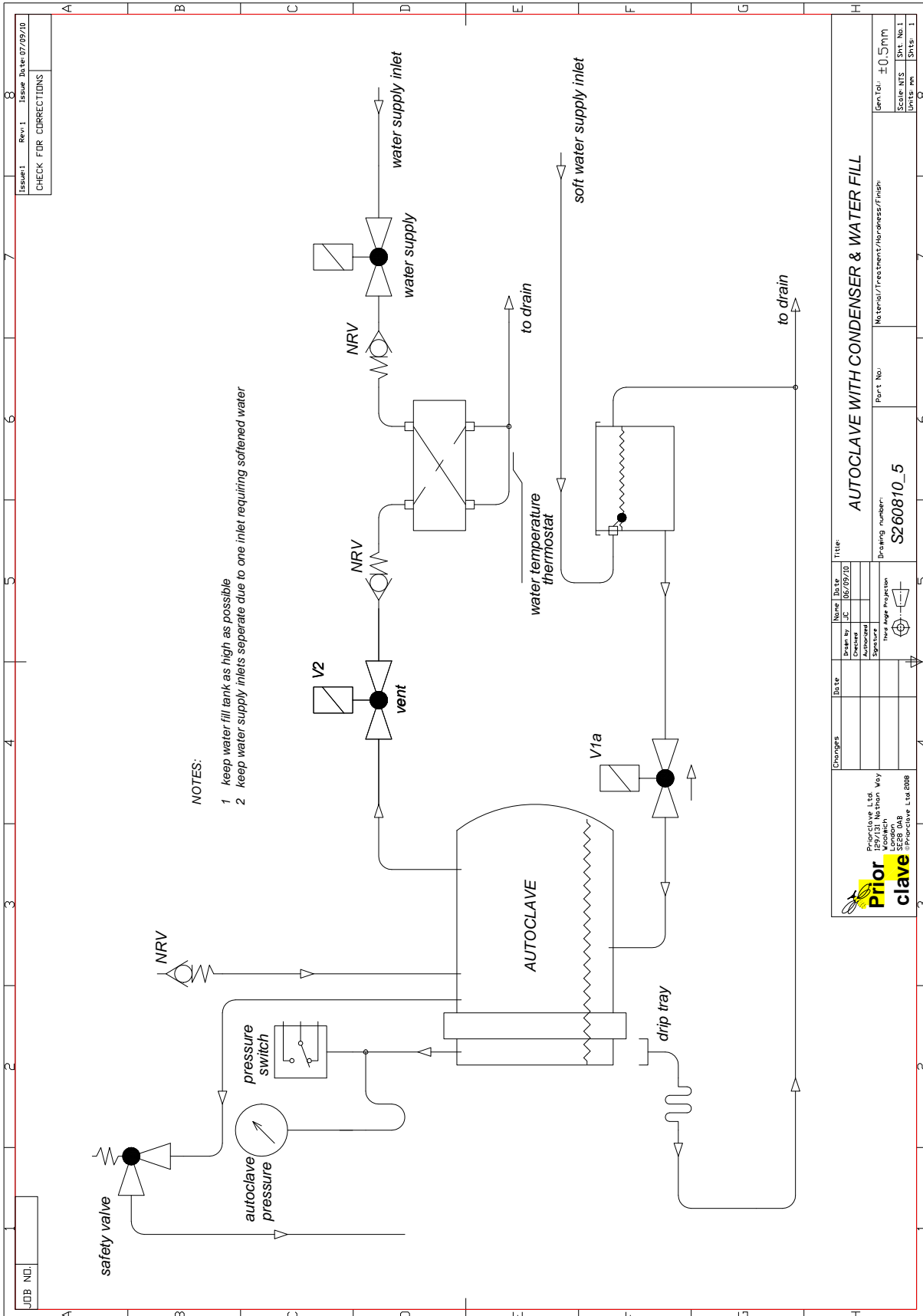

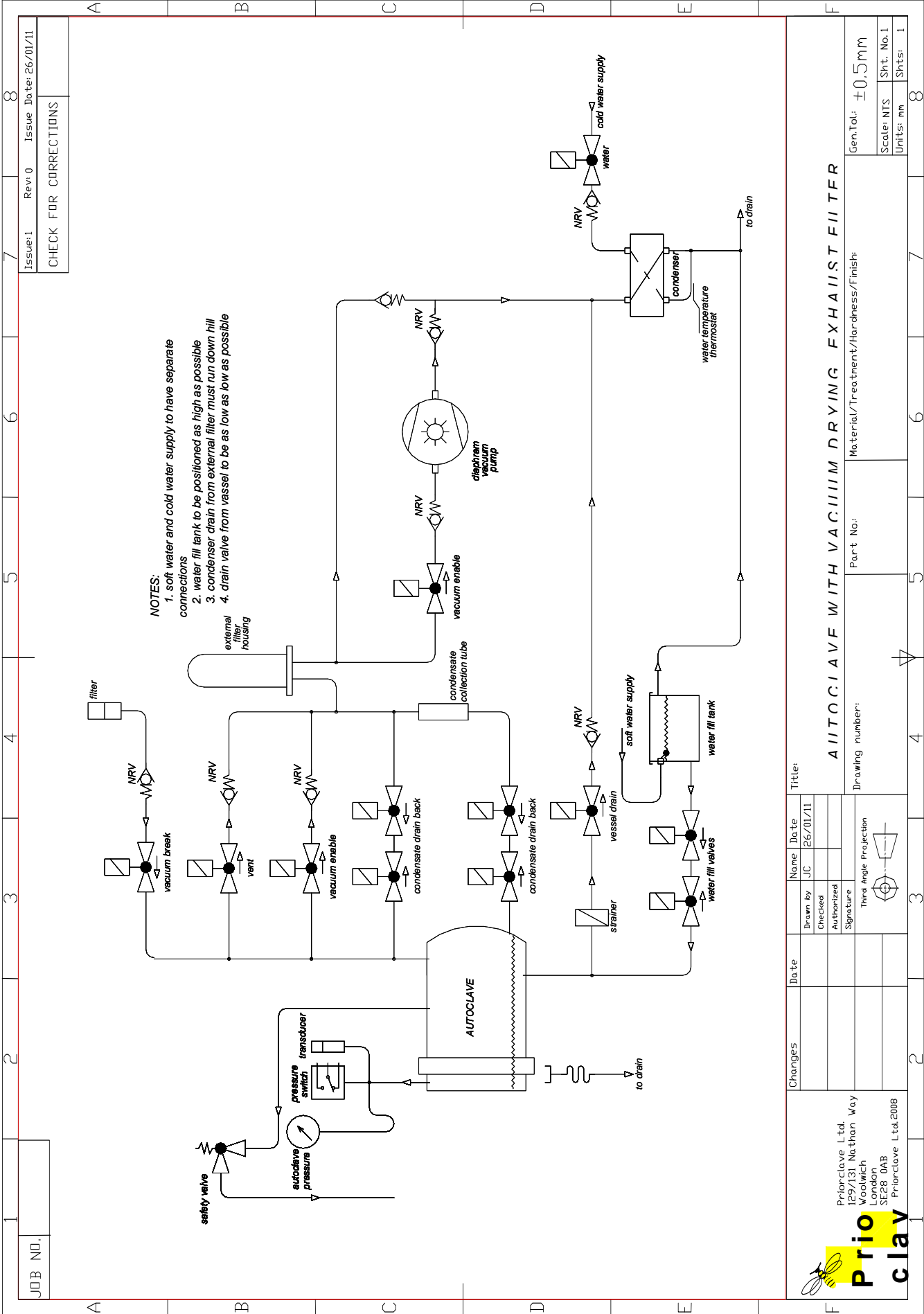

JOB NO.		Issue: 1		Rev: 0		Issue Date: 26/01/11	
CHECK FOR CORRECTIONS							

Changes		Date		Name		Date		Title	
				JC		26/01/11			
				Checked					
				Authorized					
				Signature					
				Third Angle Projection					
Priorclave Ltd. 129/131, Nathan Way Woolwich London SE28 0AB Priorclave Ltd. 2008				Part No:		Material/Treatment/Finish:		Gen. Tol: ±0.5mm	
				Drawing number:		A110CLAVE WITH VACUUM DRYING EXHAUST FILTER		Scale: NTS	
								Units: mm	
								Sht. No. 1	
								Shts: 1	

## **Appendix E - Other Options Fitted**





# Opening Instructions

Your Priorclave Autoclave is electrically locked. In order to open it and access the full operating instructions it will first be necessary to connect it to a suitable electrical supply as follows:

## UK & EC power supplies



## Connection to UK & EC power supplies

To connect your Priorclave to the power supply simply plug the fitted plug provided into a suitable socket. If the plug is removed the autoclave must be connected via a plug and socket or isolator rated for at least 13 Amps.



This Equipment **MUST** be earthed

**If a cable and plug has been fitted to the autoclave there should be no need for any further electrical installation.**

## Connection to other power supplies

For areas where a 110V single phase or 220V three phase supply is usual the autoclave can be connected across phases to operate on a 220V supply.

If not already supplied as a supplementary sheet to this sheet then separate instructions are available by contacting Priorclave - [service@priorclave.co.uk](mailto:service@priorclave.co.uk) – making sure to include the autoclave serial number in your correspondence.

After connecting the autoclave to a suitable power supply it can be opened as follows:



1. Check electricity supply is **ON**, and that the power switch is switched **on**.
2. As you are powering up the autoclave for the first time the fault code **F004** will be displayed on the temperature display. You may ignore this at this stage as opening the autoclave and filling it with water will reset this error code.
3. Press the '**Door**' button on the control panel there will be a bleep and the message '**Hold**' will be displayed in the temperature display. Wait for a short time until the temperature display returns to normal, there is another bleep and the door indicator illuminates. The door button can now be pressed again to release the lock.
4. Move the locking handle to the right until it reaches its safety stop. Do not move the handle until the lock has withdrawn as this may lead to damage.
5. Release the safety catch by pushing it down with your thumb and move the locking handle to the top of its travel. The door can now be opened.