



## **Operation & Maintenance Manual**

**Top Loading Direct  
Steam Heated  
Priorclaves**





## INTRODUCTION

PriorClave autoclaves are a range of general-purpose laboratory autoclaves intended primarily for media preparation, the making safe of ordinary laboratory and pathological waste and other apparatus sterilisation purposes. The autoclaves are manufactured to a high standard and feature a number of patented innovative design features. The sophisticated **TACTROL** microprocessor control system provides a very simple method of setting even the most complex cycles. The machines have been designed from the outset for easy and safe operation and maintenance.

Properly looked after your autoclave should give years of valuable and trouble free service.

### PRIORCLAVE SERVICE

**Serial Number:**

**Date of Manufacture:**

**Software Version:**

Please quote the above when asking for parts or service:

#### PRIORCLAVE LIMITED

129 /131 Nathan Way  
West Thamesmead Business Park  
London  
SE28 0AB

**Telephone:** +44 (0)20-8316-6620

**Fax:** +44 (0)20 8855-0616

**E-mail:** [sales@priorclave.co.uk](mailto:sales@priorclave.co.uk)

**Website:** [www.priorclave.co.uk](http://www.priorclave.co.uk)

or your local agent:

This Page Has Been Deliberately Left Blank

## IMPORTANT NOTICES

- Priorclave Pressure Vessels and Autoclaves are manufactured according to BS2646 Part 1 (1993). It is recommended that the user/operator ensures that the autoclave is installed, operated, maintained and tested according to parts 2,3,4 & 5 of this standard for safe and effective use and that an adequate logging record of operation and maintenance be established.
- Before despatch from our works all Priorclaves are subjected to rigorous electrical safety tests to the appropriate standards. Should you or your contractors carry out further insulation and flash tests as part of your internal procedures please disconnect the switch mode power supply before testing. Failure to do so will result in a test failure and may lead to corruption of the microprocessor memory which cannot be covered by our warranty.

### Safety

- If you are unclear about any aspects of this manual, the use and operation of the autoclave or your autoclave process please contact Priorclave or your authorised Priorclave dealer before proceeding.
- Always wear gloves a facemask and adequate protective clothing when unloading an autoclave and ensure that the workload does not exceed safe limits.
- Priorclave are pleased provide training for operators in the use of their autoclaves at a small extra charge.

### Thermal Lock

- The safety Thermal Lock (80°C door retention device) has been set in accordance with the load and procedure defined in paras. 3.3.3.2.3 and 3.3.3.3 of BS2646 Part 5:1993.
- The relatively light load defined under this procedure may not be appropriate to the load to be autoclaved in your Priorclave. Therefore, to ensure compliance with Health & Safety Executive Guidance Note PM73 'Safety at Autoclaves' and to avoid possible injury you are strongly advised to have your autoclave with its normal working load formally validated, and the thermal lock set up accordingly by properly trained personnel.

### Stainless Steel Pressure Vessels.

- Vessels are manufactured from grade 316 stabilised stainless steel, designed built and tested in accordance with BS5500 category 3 as required by BS2646 Part 1. Grade 316 stainless steel is employed to reduce the corrosive effects of substances such as hydroxides and chlorine. However we recommend that the interior of the vessel is kept free of such potentially harmful substances and is regularly cleaned out with soft water. The use of chlorine based or other aggressive cleaners is not recommended. Exposure to such chemicals could damage the surface finish and the integrity of the pressure vessel and door. Care should also be taken not to routinely introduce such chemicals where they are used to pre-wash items that form part of the load. In such cases the items should be thoroughly rinsed before autoclaving.

### Product Life

- Due to fatigue occurring in normal use the life of all pressure vessels is finite regardless of corrosion, erosion or other damage. Using calculations from BS5500, and assuming working at the maximum working pressure of 2.4 bar this gives the autoclave vessel a projected fatigue life of 15,000 operating cycles. The lifespan of the autoclave will obviously depend upon frequency of use, but for example (based on a 365 day working year) if the autoclave is used two or four times per day this gives a working life of 20.5 to 10.2 years respectively. Your own usage of the autoclave should be considered to determine the actual lifespan of the autoclave.

## Cleaning

- This equipment contains sensitive electrical equipment. Although designed to withstand laboratory conditions it is not designed for wet cleaning. Cleaning this equipment by hosing down may cause damage, invalidating the warranty, and may cause an electrocution hazard.
- External cleaning should be carried out with a damp cloth or with proprietary, non-abrasive cleaners.

## Servicing and Maintenance of Priorclave Autoclaves

- Priorclave Laboratory Autoclaves are complex pressure systems designed and built to special regulations and as such should only be serviced or maintained by properly trained personnel. Priorclave Ltd. cannot be held responsible for hazards or damage resulting from work carried out on the pressure system by untrained or unauthorised personnel. If in doubt please contact Priorclave Service or your nearest authorised dealership.

## CE Marking

The CE mark applied to this autoclave is applied in relation to the EMC (Electromagnetic Compatibility) directive and the Low Voltage directive of the European Community. This indicates that this Priorclave autoclave meets the following technical standards :

- **EN50081-1**  
Electromagnetic Compatibility. Generic Emission Standard. Residential, Commercial & Light Industry.
- **EN50082-1**  
Electromagnetic Compatibility. Generic Immunity Standard. Residential, Commercial & Light Industry.
- **BS EN 61010-1: 1993**  
Safety Requirements for Electrical Equipment for Measurement, Control and Laboratory use.
- **BS EN 61010-2-041: 1996**  
Safety Requirements for Electrical Equipment for Measurement, Control and Laboratory use; Part 2-041, Particular Requirements for Autoclaves using Steam for the treatment of Medical Materials and for Laboratory Processes.
- **EN 46001: 1997**  
If used for the sterilisation of medical equipment within the scope of the Medical Devices Directive the CE mark is applicable to this directive. If using this equipment for the sterilisation of medical equipment your attention is drawn to the need for the consideration of the standards that may be applicable to the type of equipment to be sterilised. If in doubt consult the manufacturer. In all cases autoclaves used for the sterilisation of medical devices must be validated in accordance with EN554 before use. This product is manufactured in accordance with EN46001.

## Pressure vessels

- **PD5500 2000**  
Unfired fusion welded pressure vessels
- **BS2646 1996**  
Autoclaves for sterilisation in laboratories

Conformity assessment modules B1 + D of the European Pressure equipment directive have been applied to ensure compliance with the essential safety requirements.

A "Declaration of Conformity" in accordance with the above standards has been made and is on file at:

**Priorclave Ltd.**  
**129 /131 Nathan Way**  
**West Thamesmead Business Park**  
**London SE28 0AB**

## Environmental Conditions

This equipment has been designed for safe operation within the following environmental conditions:

- Indoor Use.
- Altitude up to 2,000 M. (See Appendix B - Steam Table for special conditions affecting calibration for operation at elevated altitudes).
- Temperatures between 5°C and 40°C.
- Maximum Relative Humidity of 85% at any temperature between 5°C and 40°C.
- Mains Supply Voltage Variations not exceeding  $\pm 1.10\%$  of that shown on the Serial Plate.

- **Electromagnetic Interference**

This equipment has been designed to comply with the requirements for immunity from electromagnetic interference under normal conditions of use. Care should be taken when siting the equipment however, to avoid interference from potential extreme sources of interference such as MR scanners or x-ray equipment.

## Hazard Statement

Electrical Hazard Stickers



When this sticker has been placed on a removable panel the power must be switched off before the panel is removed. There may be a number of areas behind the labelled panel that constitute an electrical shock hazard. All such panels are service access panels only and should not be removed unless there is a full understanding of the equipment.

# CONTENTS

<b>INTRODUCTION</b> .....	<b>1</b>
<b>IMPORTANT NOTICES</b> .....	<b>3</b>
<b>CONTENTS</b> .....	<b>6</b>
<b>LAYOUT DIAGRAM</b> .....	<b>7</b>
<b>OPERATING SUMMARY</b> .....	<b>8</b>
<b>PREPARING YOUR PRIORCLAVE FOR USE FOR THE FIRST TIME</b> .....	<b>10</b>
Preparing your Priorclave for use.....	10
Positioning .....	10
Installation.....	10
Electrical.....	10
Steam Supply & Connection.....	11
Drainage .....	11
Commissioning.....	13
Full Commissioning and Performance Testing.....	14
<b>CONTROL PANEL LAYOUT</b> .....	<b>15</b>
<b>OPERATION</b> .....	<b>16</b>
Aborting the Cycle.....	21
<b>CHANGING DATE &amp; TIME</b> .....	<b>22</b>
<b>OPERATION WITH OPTIONS &amp; ACCESSORIES</b> .....	<b>23</b>
Multi Program Memory Options.....	23
Setting Lock Keyswitch Option .....	23
Load Sensed Process Timing.....	23
Printer.....	24
Chart Recorder.....	25
Internal Validation System.....	25
Air Intake Filter .....	25
Vent Filter.....	26
<b>VACUUM OPTIONS</b> .....	<b>26</b>
Pre-Cycle Vacuum .....	26
Drying Cycle - Suitable for Non Media Loads Only.....	26
Vacuum Cooling - Suitable for Non Media Loads Only.....	26
<b>WARNING INDICATORS AND FAULT CODES</b> .....	<b>28</b>
<b>MAINTENANCE</b> .....	<b>30</b>
Weekly Maintenance .....	30
Monthly Maintenance.....	31
Quarterly Maintenance .....	31
General Maintenance .....	33
<b>SPARES LIST</b> .....	<b>36</b>
<b>Specification Tables</b> .....	<b>39</b>
<b>NOTES</b> .....	<b>41</b>
<b>APPENDIX A - FAULT FINDING &amp; RECTIFICATION GUIDE</b> .....	<b>43</b>
<b>APPENDIX B - STEAM TABLE</b> .....	<b>45</b>
<b>APPENDIX C - WIRING DIAGRAMS</b> .....	<b>47</b>
Output Board Designations.....	47
<b>PIPEWORK SCHEMATIC</b> .....	<b>50</b>
<b>APPENDIX D - OTHER OPTIONS FITTED</b> .....	<b>51</b>



# LAYOUT DIAGRAM



1. Cycle Progress Display	7. Time Display & Setting Buttons
2. Door Button & Indicator	8. Program Buttons & Indicators (Optional)
3. Vent Button & Indicator	9. Printer (Optional)
4. Start Button & Indicator	10. Setting Lock Keyswitch (Optional)
5. Option Setting Buttons & Indicators	11. Thermal Lock Keyswitch
6. Temperature Display & Setting Buttons	

# OPERATING SUMMARY

**N.B. Before proceeding please check the specification sheet at the front of this manual to establish which options and accessories, if any, are fitted to your Priorclave. This will determine whether you will need to read the instructions for these options later in this manual or in Appendix D.**

- 1) Check electricity and Steam supplies are **ON**.

Press the 'door' button on the control panel there will be a bleep and the message 'hoLd' will be displayed in the timer display. Wait for a short time until the timer display returns to normal, there is another bleep and the door indicator illuminates. The door button can now be pressed again to release the lock.

**NOTE: Do not pull the handle against the lock before it has released or damage to the locking solenoid may result.**

- 2) Open the autoclave door as described below:

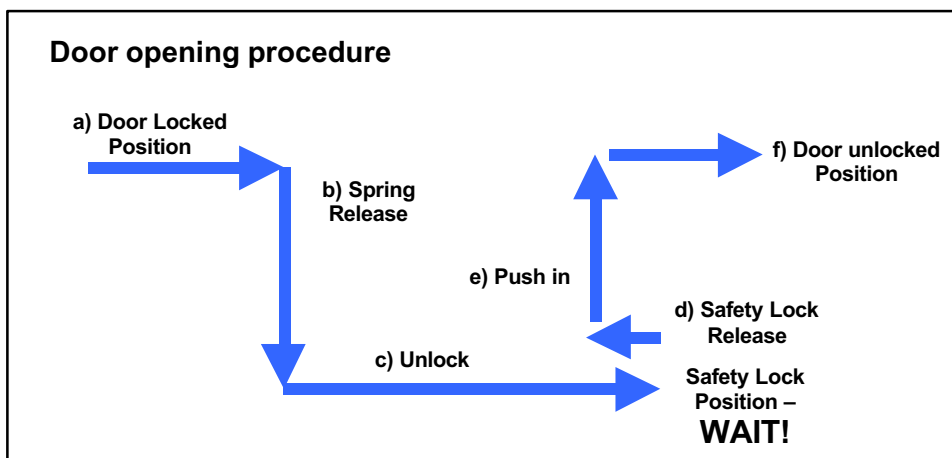

- a) Move the locking handle to the right
  - b) The handle will now spring out into its unlocking position
  - c) Move the handle fully to the right to unlock the door. The handle is now in its safety lock position, allowing any residue of pressure inside the autoclave to escape harmlessly.
  - d) Move the handle slightly to the right to release it from the safety position
  - e) Push the handle in as far as it will go
  - f) Move the handle fully to the right to its parked position
- 3) With the lid unlocked, carefully lift to the open position.  
**N.B Take care whilst the door is open that it is fully against its stops and does not fall. The door is heavy and could cause harm.**
  - 4) Load the autoclave with baskets or containers.
  - 5) Set the temperature as required using the up/down keys.
  - 6) Set the process time as required using the up/down keys.
  - 7) Set / select other functions ie free-steam, rapid cooling etc., as required and if fitted.
  - 8) Carefully lower the pressure lid and secure as follows:
    - a) Move the locking handle to the left to release it from its parked position
    - b) The locking handle will now spring out to its locking position
    - c) Move the locking handle fully to the left to lock the autoclave door
    - d) Push the handle in fully against the spring

- e) Move the handle fully to the left into its 'park' position

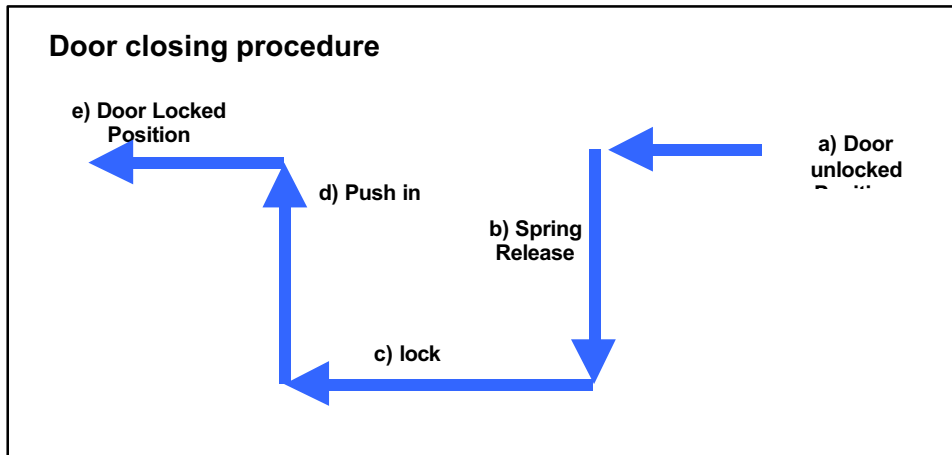

- 9) Wait a few seconds for the 'start' indicator to illuminate, and press the 'start' button to begin the cycle.

### Cycle Abort and Thermal Lock Override

#### **Aborting a cycle**

To abort the cycle at any stage press the 'Start Button'

#### **Thermal Lock Override**

First abort the cycle as above. After checking that there is no pressure within the autoclave turn the thermal lock key to the right hold it there. Press the 'Door' button once, keeping the thermal lock key held over. Wait during the **hoLd** display until the 'Door' indicator illuminates. Keep the key held and press the 'Door' button once to unlock the door. The keyswitch can now be released and the door opened as above. If the key is released at any stage the procedure must be repeated to open the door and reset the display.

# PREPARING YOUR PRIORCLAVE FOR USE FOR THE FIRST TIME

## *Preparing your Priorclave for use*

Unpack the autoclave and check against the delivery note that all items ordered have been delivered.

Any shortages or damage must be reported to Priorclave Limited within 7 days of delivery.

## *Positioning*

The autoclave may be positioned flush to units, walls etc. on both sides, but a gap of at least 204mm (8") must be left at the back of the machine to allow the door to open fully and to ensure the circulation of air. This will also provide a space for pipework and electrical connections.

The autoclave has castors fitted at the back to allow easy mounting and positioning and should ideally be positioned within easy reach of a suitable isolatable electrical supply and drain (if required). See Installation.

All autoclaves during their process cycle will release steam (unless plumbed into a drain) and heat, and this should be taken into consideration when choosing a site in your laboratory in which to install your autoclave.

## *Installation*

### **Electrical**

To connect your Priorclave to the power supply simply connect a suitable cable from your isolator or power socket to the isolator at the rear of the unit. Wiring is as shown in the diagram.

The power supply to the Autoclave should be run from a suitably rated isolator or a 13A power socket (see specification sheet) and connected to the isolator as in the diagram. Sufficient length of cable should be used to allow the autoclave to be pulled out and worked on from the back. The earth, live and neutral feeds should all be capable of carrying the required amperage. If required the neutral line must be nominally at earth potential, must not be fused and the equipment must be earthed.

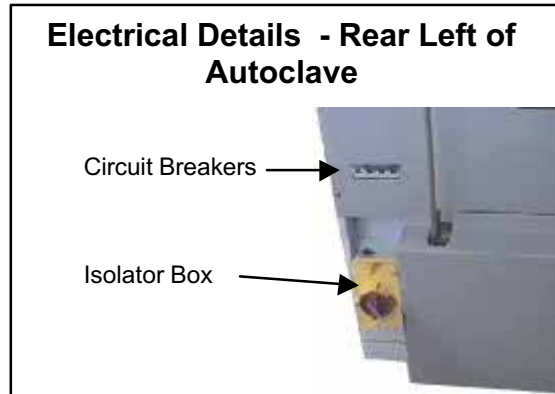

- **7 KW SINGLE PHASE**

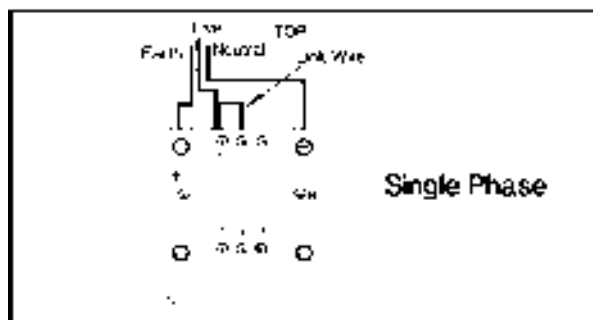

Diagram A

The power supply to the Autoclave should be run from a suitable 30 Amp isolator and connected to the isolator as in diagram (A). Sufficient length of cable should be used to allow the autoclave to be pulled out and worked on from the back. The earth, live and neutral feeds should all be capable of carrying 30 Amps. The neutral line must be nominally at earth potential, must not be fused and the equipment must be earthed.

NB. Single phase 7 kW machines may be converted at a later date, if required, to 10.5 kW 3 phase heating by rewiring as described below.

- **3 PHASE – Liquid Ring Vacuum Pumps**

The power supply should be a 3 phase and neutral isolated supply, rated at 15 Amps per phase and connected to the isolator as in diagram (B). Sufficient length of cable should be used to allow the autoclave to be pulled out and worked on from the back. The cable used to the earth line and neutral feeds should be capable of carrying the per phase amperage of the supply. The neutral line must be nominally at earth potential and must **NOT** be fused. This equipment must be earthed.

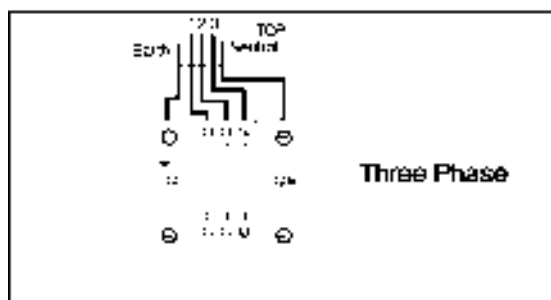

Diagram B

### Electrical - General

Heating is by 2, 3 or 6, 3.5 kW immersion elements depending on the heater power of your autoclave.

The main circuit breakers are located at the back of the autoclave above the mains inlet (see above). The main processor control board is independently fused at its power supply. See Wiring Diagram - Appendix C - for more details.



Depending on the model and the options fitted to the autoclave one or two 3 pin 230V power sockets may be fitted to the back of the autoclave. These are marked with the symbol shown above are intended for use only with the Priorclave accessory supplied for use with them which is fitted with the appropriate plug.

### Steam Supply & Connection

The autoclave requires a dry saturated steam supply regulated to approximately 40psig, supplied via a 100 mesh strainer. A suitable pressure reducing valve should be provided along with 2 x 100mm pressure gauges showing regulated and unregulated pressure, these should be located within view of the intended site of the autoclave. A condensate trap set should be located in the supply within 1m of the connection to the autoclave. If required for the satisfactory operation of the reducing valve a condensate trap set should be located in the supply to the pressure reducing valve. If a steam quality test port is required this should be incorporated into the supply pipework.

A manual isolation valve should be fitted to the steam inlet line (one is supplied with the autoclave).

### Drainage

BS2646 Part 2 states that autoclaves used for processing laboratory waste should always be connected to a drain to prevent contaminated steam and condensate from fouling the

laboratory. The drain-pipe should be connected to a sealed drain cover and a high level vent pipe should be fitted discharging outside the laboratory as in the diagram below. If possible it is always advisable to connect the autoclave to a drain to cut down on the amount of steam discharged into the laboratory. A compression fitting should be incorporated in the drain-pipe in an easily accessible location to enable easy disconnection for maintenance purposes.

An air gap must be left between the drain outlet pipe and drain water level to prevent possible 'suck back' of drain water when the autoclave cools.

All drain piping should head downward towards the drain to prevent water collecting in the pipe.

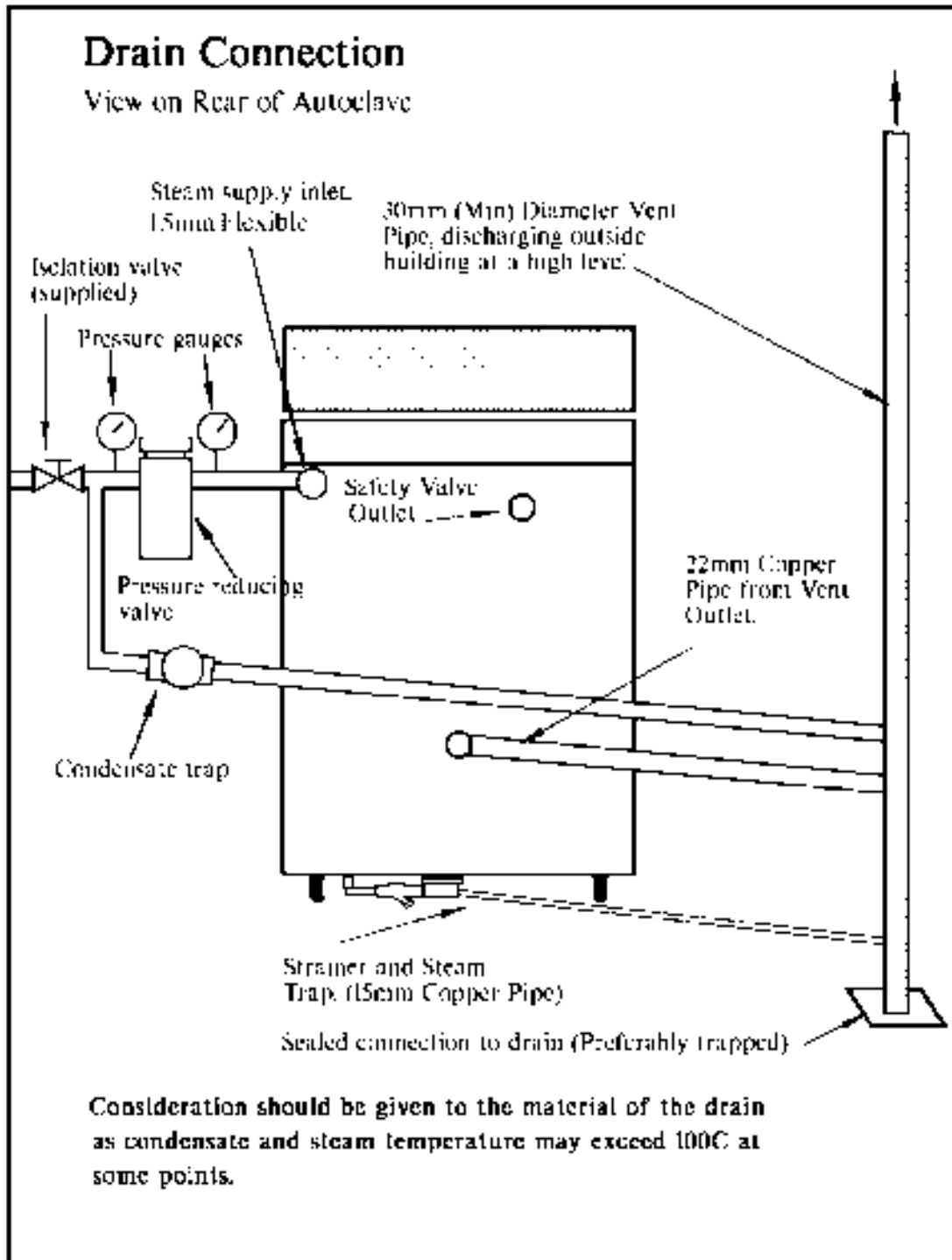

**THE SAFETY VALVE OUTLET (MARKED 'SAFETY') MUST NOT BE CONNECTED TO A DRAIN. IT IS A REQUIREMENT OF B.S. AND HEALTH AND SAFETY STANDARDS**

## THAT A STEAM DISCHARGE MUST BE VISIBLE SHOULD THE SAFETY VALVE OPERATE.

### Vacuum Pump

If a vacuum system is to be fitted to your Priorclave the pump is supplied in a separate housing complete with two flexible connection hoses.

The first hose should be connected between the autoclave and the vacuum pump inlet and second from the vacuum pump outlet and the drain.

### Drain Condensers

If your Priorclave is fitted with a drain condenser system then this should be connected to a suitable cold water supply and the outlet of the condenser connected to the drain.

**Consideration should be given to the discharge from the Vent and Safety Valve outlets, which should be directed in such a way as to not cause a hazard. This will be determined by the location of the autoclave.**

**Once properly installed your Priorclave is now ready for use.**

### Commissioning

Priorclave Autoclaves are given a full operational test before leaving the factory and as such arrive ready for immediate use after initial installation. It is advisable however to run a simple cycle with the autoclave empty before processing a working load to check that no problems have arisen during transport.

If commissioning has been ordered with the autoclave this will be carried out by a Priorclave technician otherwise follow this simple procedure to check the operation of your Priorclave.

- 2) Check that the power is **ON** at the wall isolator and that the steam supply is available, at the correct pressure and on.
- 3) Switch on the power at the isolator at the back of the autoclave (for position see diagrams above). All indicators will light momentarily and a sounder will bleep. This enables the indicators to be checked.
- 4) Press and release the **door** button, which will bleep, and wait for a short time (about 20 seconds) until the **door** indicator illuminates and the sounder bleeps again. On pressing the **door** button a second time, you will hear the locking bolt withdraw.
- 5) Open the autoclave door as described below:

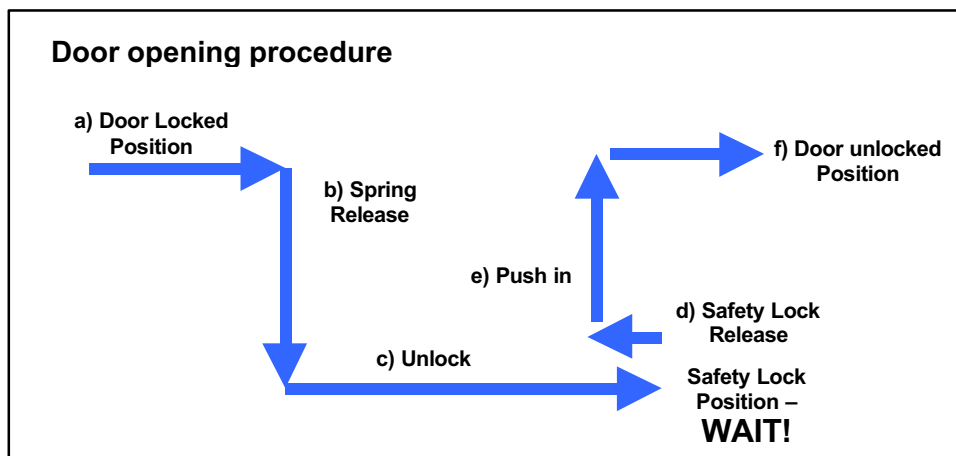

- a) Move the locking handle to the right
- b) The handle will now spring out into its unlocking position
- c) Move the handle fully to the right to unlock the door. The handle is now in its safety lock position, allowing any residue of pressure inside the autoclave to escape harmlessly.
- d) Move the handle slightly to the right to release it from the safety position

- e) Push the handle in as far as it will go
- f) Move the handle fully to the right to its parked position
6. Set the temperature to 121°C and the process time to 15 minutes using the arrows under the displays.
7. Carefully lower the pressure lid and secure as follows:
  - a) Move the locking handle to the left to release it from its parked position
  - b) The locking handle will now spring out to its locking position
  - c) Move the locking handle fully to the left to lock the autoclave door
  - d) Push the handle in fully against the spring
  - e) Move the handle fully to the left into its 'park' position

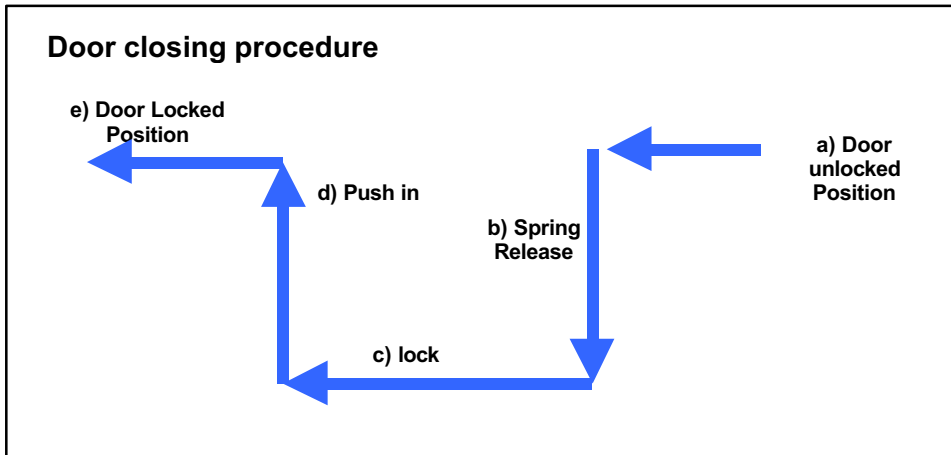

8. The **start** indicator should now be lit.
9. Press the **start** button to begin the cycle.
10. During the cycle, check that there are no problems during heat-up and process.

Following successful completion of the commissioning cycle your Priorclave is ready to process its first working load.

Please refer to the **Operation** section later in this manual before running your first working load as this gives further details on operation of the autoclave and on the control options which may be fitted.

If you experience any problems during this procedure please contact Priorclave service or your local agent.

## **Full Commissioning and Performance Testing**

If you are having the unit commissioned by a Priorclave technician this will be a simple matter of checking for correct installation, checking that all functions are operating correctly, and familiarising you with the autoclave. There are however some benefits that can be gained from having your Priorclave commissioned to suit your particular loads and requirements. Some examples of settings that can be optimised during commissioning, and the advantages these can provide are listed below.

- Establishing optimum freesteam temperatures for effective air displacement.
- Establishing optimum freesteam time for effective air displacement, whilst eliminating unnecessary time and energy consumption.
- Establishing optimum process time and temperature to ensure complete sterilisation, whilst maintaining minimum cycle time and energy consumption.
- Setting thermal lock release temperature to suit your particular load, to eliminate unnecessary cooling time whilst ensuring safety.

If you feel that any, or all of the above would be of use to you then please contact Priorclave Service.



# CONTROL PANEL LAYOUT

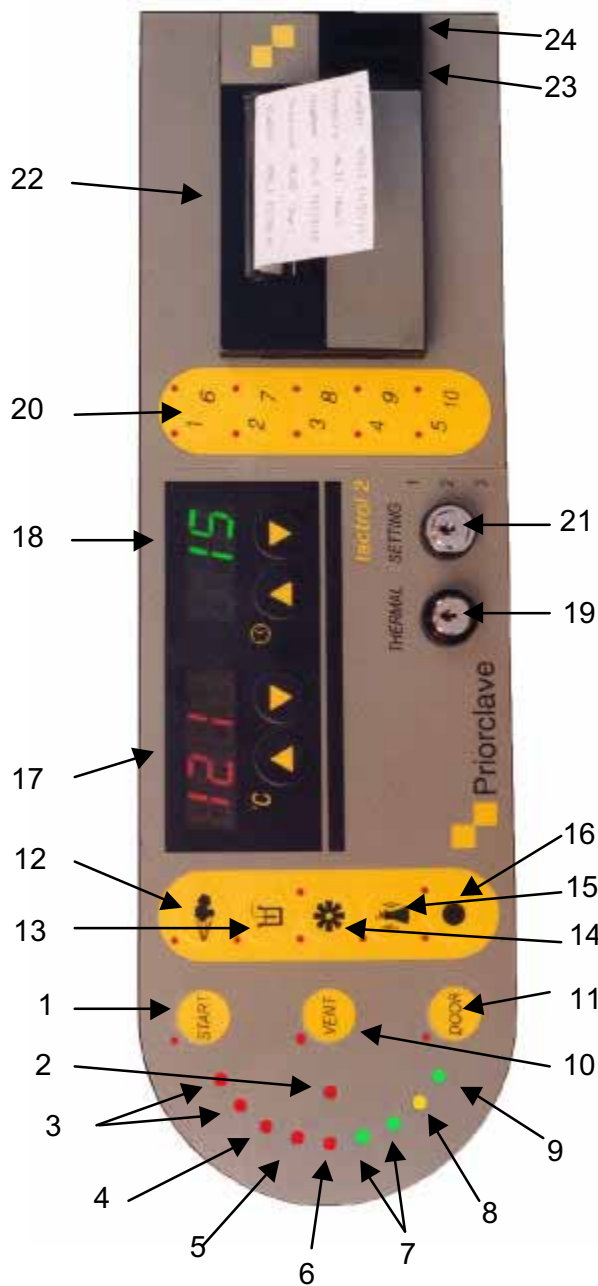

## Key

1. Start Button/Indicator
  2. Pre-Cycle Vacuum Indicator
  3. Heat Indicators
  4. Freesteam Indicator
  5. Heat-up to Process Indicator
  6. Process Indicator
  7. Cooling Indicators
  8. Complete Indicator
  9. Media Warming Indicator
  10. Vent Button/Indicator
  11. Door Button/Indicator
  12. Freesteam Select Button/Indicator
  13. Load Sensed Process Timing Select Button/Indicator (optional)
  14. Cooling Select Button/Indicator
  15. Media Warming Select Button/Indicator
  16. Vacuum Select Button/Indicator (optional)
  17. Temperature Display/Setting
  18. Timer Display/Setting
  19. Thermal Lock Keyswitch
- Optional Fittings**
20. 5/10 Program Memory Buttons/Indicators
  21. Setting Lock Keyswitch
  22. Printer
  23. Paper Advance Button
  24. Printer Door Open Button

# OPERATION

**BEFORE USING YOUR PRIORCLAVE FOR THE FIRST TIME CHECK THAT THE CIRCUIT BREAKERS AND ISOLATOR (AT THE BACK OF THE AUTOCLAVE) ARE SWITCHED ON AND THAT THE STEAM SUPPLY IS AVAILABLE, CORRECTLY REGULATED AND CONNECTED.**

N.B. Before proceeding please check the specification sheet at the front of this manual to establish which options and accessories, if any, are fitted to your Priorclave. This will determine whether you will need to read the instructions for these options later in this manual or in Appendix D.

## Opening the Door.

- 1) Switch on the power at the isolator. All indicators will light momentarily and a sounder will bleep. This is to enable the indicators to be checked. The **start** indicator should now be lit. Press and release the **door** button, which will bleep, and wait for a short time (about 20 seconds) until the **door** indicator illuminates and the sounder bleeps again. During the waiting time the temperature display will show **hold**, confirming that the autoclave is waiting during its safety delay. On pressing the **door** button a second time, you may hear the locking bolts withdraw. You may now open the door as described below. (The **vent** button will light when the **door** button is pressed and remain lit after the cover is opened.)

**NOTE: Do not pull the cover against the lock before it has released or damage to the locking solenoid may result.**

- 2) Open the autoclave door as follows:
  - a) Move the locking handle to the right
  - b) The handle will now spring out into its unlocking position

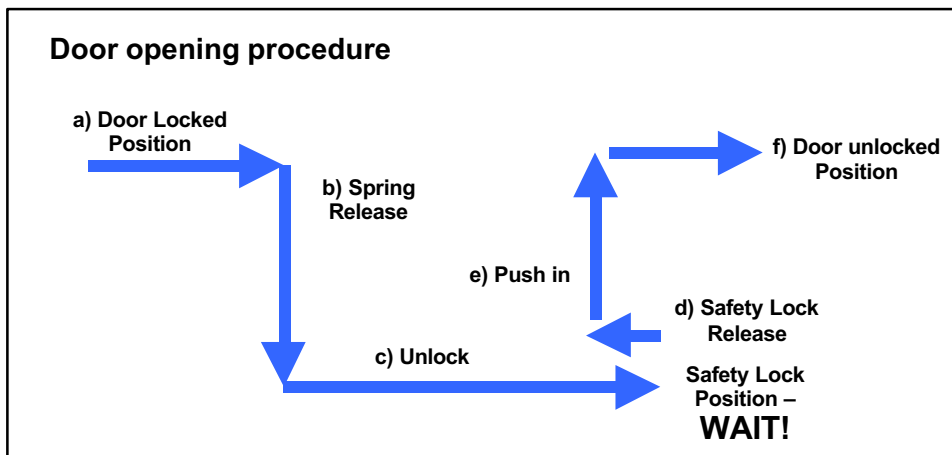

- c) Move the handle fully to the right to unlock the door. The handle is now in its safety lock position, allowing any residue of pressure inside the autoclave to escape harmlessly.
- d) Move the handle slightly to the right to release it from the safety position
- e) Push the handle in as far as it will go
- f) Move the handle fully to the right to its parked position

**NOTE: Care should be taken when opening the lid as it will be hot and steam may be released. Heatproof gloves and a faceshield should always be worn when unloading autoclaves.**

**N.B Take care whilst the door is open that it is fully against its stops and does not fall. The door is heavy and could cause harm.**

### 3) Loading

The autoclave can now be loaded with the items to be sterilised in either baskets, or watertight discard containers in the case of waste loads, which may leak liquids when autoclaved.

Care should be taken when loading the baskets or containers not to pack them too tightly with material. Ample room must be allowed for steam to penetrate the load properly or full sterilisation will not be achieved. When using autoclave bags these should be left open with the top of the bag rolled outwards, exposing the load to the steam inside the pressure vessel.

Care should also be taken that the contents of bags and containers are not able to spill over into the body of the autoclave vessel. Any such spillage could block pipes and valves and will not be covered by the warranty.

**N.B.** Tests have shown that the depth of unperforated discard containers should be no greater than 180mm (7") for effective air displacement from the load. Suitable containers are available from Priorclave.

### 4) Settings.

Once the autoclave has been satisfactorily loaded the controls should be set for the process cycle that you require.

If your autoclave has a setting lock fitted this must be set to **position 3**.

#### **Sterilising Temperature & Time Settings.**

The Medical Research Council has recommended the following temperatures and times as being sufficient for complete sterilisation in autoclaves:

**126°C for 10 minutes.**

**121°C for 15 minutes.**

**115°C for 30 minutes.**

These temperatures and times relate of course to load temperatures and the aim in setting a cycle should be to achieve one of the above criteria in the coldest part of the load. Some loads however are sensitive to elevated temperatures for prolonged periods, making full achievement of the above impractical. However the disinfection of such loads after a short cycle, without necessarily reaching full Sterilising Temperature, is usually sufficient for most purposes.

Should you require a more precise method then the optional **Load Sensed Process Timing** may be of assistance for certain load types. If your autoclave is fitted with this option please refer to the description later in this manual.

Since there is a time and temperature 'lag' between the temperature controller probe and the load, this should be compensated for either by increasing temperature or process time, or by including in the cycle a period of free steaming with the vent open at 100°C. This can be achieved by pressing in the **vent** button manually and releasing it manually. Alternatively, the **Automatic Freesteaming** Option will perform this function automatically if the option is selected.

If you have an interest in any of the options mentioned above, which can quite easily be retro-fitted, please contact Priorclave Technical Services Department.

In conclusion, when setting up the autoclaving cycle a large safety margin should be allowed within the settings.

More precise settings can be assessed by carrying out a 'worst load' test. (See commissioning).

### 5) Setting the process time

The process timer can be set to a time up to 999 minutes. The time required is set by simply using the time up/down buttons. The set time is displayed until the set temperature is reached, then the process time begins counting down to zero in increments of one minute.



## 6) Setting process temperature

Pressing either the up or down button momentarily causes the current set temperature to be displayed. Subsequent use of the up/down buttons changes the set temperature. If no keys are pressed for a short time, the display returns to showing the current chamber temperature.



## 7) Selecting other functions

The function select keys may be used to switch the Timed Freesteaming, Cooling, Media Warming Option, and optional functions such as Load Sensed Process Timing, on or off at any time other than when a cycle is running. An indicator illuminates to show that a function has been selected. If an option is not fitted (or permitted in the selected program in multi-program memory models) pressing the appropriate key will result in a visual and audible fault being signalled and the function will not be selected.

## Automatic Timed Free-Steamming

### What is freesteaming?



Incorporating a period of freesteaming into a cycle can improve air removal in difficult loads and/or reduce temperature lag between the load and the autoclave, reducing process time at higher temperatures. Freesteaming introduces a stage during heating up to Process Temperature, when a solenoid valve at the rear of the autoclave is opened for a pre-set time. The valve opens at a factory set temperature of just above 100°C and is held open for the time set as detailed below. During this time steam is being generated in the chamber in large volumes and this creates turbulence as it passes through the load before escaping through the valve. It is this turbulence that can assist with air removal.

### Setting the freesteam time.

If freesteaming is required this is selected by pressing the **freesteam** button. The indicator lights up to show that freesteaming is selected. The time display will now flash indicating that the freesteam time, not the process time, is currently being displayed. The freesteam time can now be set (in minutes) using the up/down buttons. If no further changes are made for a short time the display stops flashing, and reverts to showing process time. If you wish to check the freesteam time or make further changes then freesteaming should be deselected, then reselected.

### Freesteam temperature setting

Timed freesteaming will commence at a temperature slightly above 100°C, which has been set at the time of manufacture. If required, this temperature may be increased by qualified personnel, and the turbulence caused by the escaping steam pressure can further assist with air removal. It is desirable however to connect the autoclave to a drain and vent pipe (as described Installation), as the release of pressurised steam into the laboratory should be avoided.

Performance can be improved even further by fitting the optional pulsed freesteaming system.

## Rapid Cooling



A powerful fan is fitted into the bodywork of the autoclave to direct cool air over the autoclave vessel.

If selected by using the **cooling** button, the cooling fan will switch on automatically during the cooling stage of the cycle. There are three possible settings for rapid cooling, and these operate as follows:

**Off** - No indicators lit.

The cooling fan does not operate at all during the cycle.

**Immediate start** - Left hand indicator lit. - 1 press of the **cooling** button.

The cooling fan starts as soon as the cooling stage is reached.

**Delayed start** - Both indicators lit- 2 presses of the **cooling** button.

The cooling fan starts after the autoclave chamber has cooled to 100°C. This setting is useful when autoclaving some fluid loads, as bringing the cooling fan on at temperatures above 100°C may reduce the chamber pressure too rapidly, causing the load to boil.

**In both cases the fan will switch off automatically when the cycle has reached the complete stage.**

**8) Media Warming**



If this highly useful feature is selected the autoclave will cool to a factory pre-set temperature of 45°C. The temperature will then cycle between approximately 45° to 55°C until the door is opened. This allows, for example, nutrient media to be held as a liquid until it is needed.

**9) Closing the pressure door**

Once you have set up the cycle parameters lower the autoclave lid, taking great care not to allow the lid to be dropped into place as this will result in damage to the closure system. Then lock the door as follows:

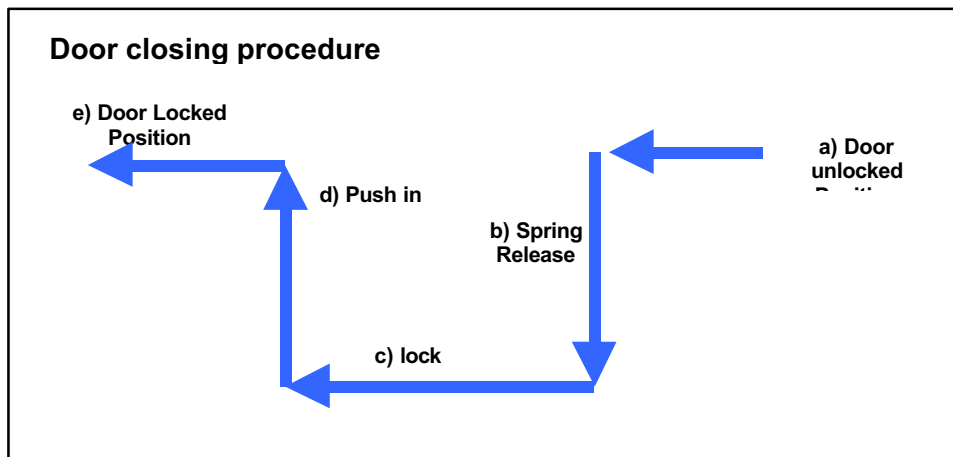

- a) Move the locking handle to the left to release it from its parked position
- b) The locking handle will now spring out to its locking position
- c) Move the locking handle fully to the left to lock the autoclave door
- d) Push the handle in fully against the spring
- e) Move the handle fully to the left into its 'park' position

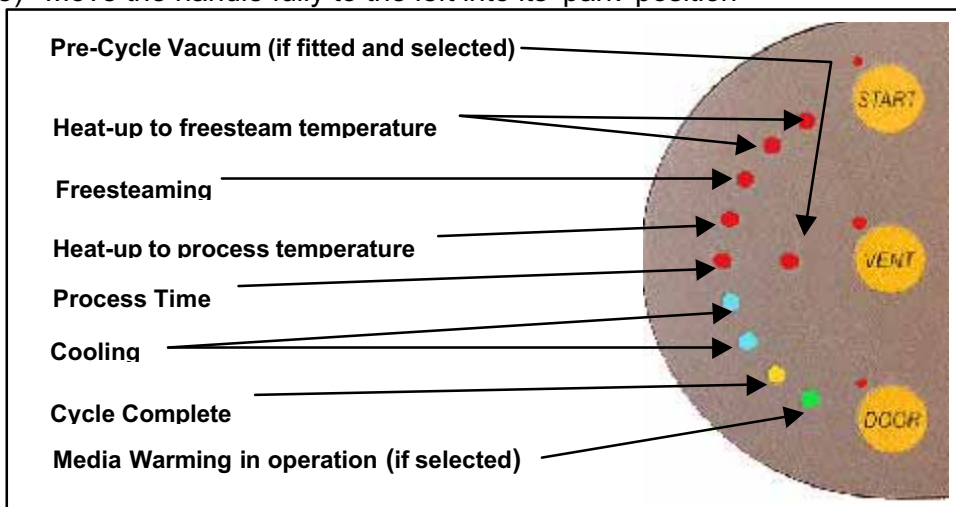

**10) Starting a cycle**

Ensure the lid is properly secured and the **start** indicator is illuminated. To start the cycle press the **start** button. The first segment of the cycle status indicator bar will

illuminate and the autoclave will now gradually heat up to process temperature. The cycle status indicator will also advance through its stages to give 'at a glance' indication of the cycle's progress.

- 11) Once a cycle has been started the function selection settings cannot be changed attempting to do so will cause a fault to be signalled. If changes are required the cycle should be aborted by pressing the **start** button again.
- 12) On Priorclaves not fitted with the setting lock keyswitch changes can be made to the process time and temperature settings once a cycle has started. At the end of the cycle the time setting will reset to its original setting.

### 13) Vent button

The **vent** button may be used at any stage during the cycle. When used it opens a large bore solenoid vent valve at the back of the machine. It may be left open for freesteaming to achieve better steam penetration of the load if **Automatic Freesteaming** has not been selected. It may also be used with certain loads as a means of rapidly venting the autoclave. If used for manual freesteaming the **vent** button must be manually released before pressure will build up and process temperature can be achieved.

**CARE SHOULD BE TAKEN IF USING THE VENT BUTTON WHEN THE AUTOCLAVE IS PRESSURISED. VENTING OF THE AUTOCLAVE UNDER THESE CIRCUMSTANCES WITH A LIQUID LOAD MAY LEAD TO THE LOAD BOILING OVER AND GLASSWARE MAY BE BROKEN.**

### 14) During the process time

Once set temperature is reached, the process time will begin to count down and the process indicator will illuminate. If the Load Sensed Process Timing Option is fitted and selected there may be a delay between the autoclave reaching set point and commencement of the process time whilst the load reaches set temperature.

During the process time a check should be made that there is correct correlation between temperature and pressure readings on the control panel. A steam table is included at the back of this manual for this purpose. The check should be made to ensure that air has been properly purged from the autoclave. Generally, entrapped air in the autoclave will be indicated by a pressure reading higher than would be expected.

If for any reason the temperature is forced outside of a pre-set band, or power to the autoclave is removed during the process time, the cycle will abort and the fault indicator will illuminate and a fault code of either **F005** or **F006** will be shown in the temperature indicator. This is to ensure that loads which have not been subjected to the required cycle parameters are not assumed to have been processed correctly. The fault condition is cancelled by:

**If no setting lock keyswitch is fitted:**

pressing the reset button on the top right hand side of the back of the autoclave,

**or**

**If a setting lock is fitted:**

turning the setting lock key to the enable position, and then to the disable position. If the lock was in the enable condition when the fault occurred, then it must first be turned to the disable position.

### 15) Cooling

After completion of the process time the autoclave moves into the cooling part of its cycle, and this is shown on the cycle status indicator in green. If **Air Cooling System** has been selected this will be switched on automatically according to the cooling strategy selected.

## 16) Thermal lock

Under normal circumstances the autoclave cannot be opened until the temperature of the load simulator probe, which has a cooling rate assimilated to a 1 litre flask or bottle of fluid, has fallen below 80°C at which point the yellow bar on the cycle status indicator will illuminate. The temperature shown by the temperature indicator will be significantly below 80°C as this measures the temperature in the open chamber space. Pressing the door button before the thermal lock has released causes a fault to be signalled. The temperature at which the thermal lock operates is factory set. This can be reset but must only be done following commissioning by qualified personnel. The thermal lock can be overridden using the keyswitch on the control panel. The keys for this switch are provided in this manual.

**OVERRIDING THE THERMAL LOCK WILL CAUSE THE MAIN VENT TO OPEN. GREAT CARE SHOULD BE EXERCISED WHEN USING THE KEYSWITCH SINCE LIQUID LOADS COULD BOIL OVER IF VENTED AT ELEVATED PRESSURES.**

There are circumstances, however when quicker access to the load is required. When this is necessary, first abort the cycle by pressing the start button. Then turn the key into its horizontal position and holding it in this position, press the **door** button and wait while the **hoLd** message is displayed until the **door** lamp illuminates. Finally press the **door** button to release the door lock. The thermal lock key can now be released. If the key is released before this stage then the **hoLd** display will not reset and the autoclave cannot be opened. To reset the display repeat the above procedure and open the autoclave.

**Great care should be exercised when using the Thermal Lock Override, especially with liquid loads. Even at temperatures below 100°C a liquid load in sealable glass containers will not be safe. For the above reasons the Thermal Lock Override key should be kept in a safe place away from the autoclave, for use only by responsible personnel.**

**Under certain cycle abort or failure conditions the thermal safety lock can latch in the locked condition. This is because the control system will always go to the safest condition if there is any uncertainty about the cycle end circumstances. To overcome this simply go through the door open or close procedure using the thermal lock override key. Operation will return to normal as soon as the next cycle is completed satisfactorily**

## 17) Cycle complete

When cooling to the 'thermal lock deactivation temperature' is complete, the **complete** indicator will illuminate, and the autoclave will emit a bleep for a short time (about 10 seconds). If the Air Cooling System is selected it will automatically switch off at this point. The autoclave is now ready to open and unload.

## 18) Media Warming

If this has been selected, the autoclave will remain at the pre-set temperature after the cycle is complete, until the door is opened or the cycle otherwise aborted.

**19) Opening the autoclave to unload and re-load for the next cycle is simply a repetition of steps 1,2 & 3.**

## ***Aborting the Cycle***

On occasions it may be necessary to abort a cycle before its completion. In order to do this, simply press the start button.

## Changing Date & Time

A number of additional control system settings can be accessed via a "Hidden Menu".

To access these settings turn & hold the thermal lock key in the override position. Press the time up or down keys. Release the thermal lock key. **1** is displayed on the temperature display, by default **0** will be displayed on the time display. The temperature display now shows the number of a list of operating parameters, the value for the parameter is shown in the time display. Scroll through the list of available parameters using the temperature up/down keys.

After no keys are pressed for eight seconds the display returns to normal.

The function of these settings is as follows:

	<b>Temp. Display</b>	<b>Time Display</b>	<b>Function</b>	<b>Action</b>
			The autoclave can be set for the cycle to start after a pre-programmed delay, for example to allow a media preparation cycle to complete shortly prior to the start of the working day. Setting the value of parameter 1 to 1 in the time display switches delayed start on.	
	1	0-24	Delayed Start Time Hour <sup>+</sup>	Enter required Start time hour (24 hour clock)
	2	0-60	Delayed Start time Minute <sup>+</sup>	Enter required Start time minute
	3	0/1	Start Delay Select On/Off <sup>+</sup>	1= ON 0= OFF
*	4	0-999	Print Interval	Enter time (minutes) between printing during process time (0= printer disabled)
	5		Year Setting	Enter Year
	6		Month Setting	Enter Month
	7		Date Setting	Enter Day of month
	8		Hour Setting	Enter Hour (24 Hr Clock)
	9		Minute Setting	Enter Minute
	10		Second Setting	Enter Second.
			<b>Scroll back up to parameter 1 to confirm the new or current time settings.</b>	
#	11	1-999	Cycle Repeats	Enter Number of Cycles Required
<sup>+</sup>	The time is set in real time, therefore the clock has to be correctly set for this to work properly. After one delayed start operation, delayed start automatically switches off, and the autoclave returns to normal operation.			
#	<b>Models fitted with optional Cycle Repeat Facility only</b>			
*	<b>Models fitted with 5 or 10 Program Memory</b> Setting marked * are program number related, and therefore should you wish to use different values for these in different programs this can be done by changing the value when the correct program is selected.			



## OPERATION WITH OPTIONS & ACCESSORIES

The following descriptions detail how to operate and gain maximum benefit from the options and accessories that may be fitted to your Priorclave.

### ***Multi Program Memory Options***

When this option is fitted, five program number keys are provided to the right of the control panel, each with two indicators. The indicators on the left are for programs 1 to 5 and those on the right for programs 6 to 10. If the Priorclave has been specified with a five program memory only the first five programs will be active. As each program number is selected, the indicator illuminates and the previously selected indicator is cancelled. Pressing the select button toggles between the two program numbers shown on the button.



When the program memory option is fitted a three-position setting lock keyswitch is fitted. These setting positions allow different levels of access to settings as follows.

- **Position 1.** Only the currently selected program can be run. Program settings cannot be changed.
- **Position 2.** All programs can be selected and run. Program settings cannot be changed.
- **Position 3.** All programs can be selected and run. Program settings can be changed freely.

**NOTE: The setting lock key can only be removed in positions 1 and 2.**

Programming of settings is the same as with the standard machine, but the required program number should be selected before setting. The settings entered can then be recalled for subsequent use by simply reselecting that program number.

### ***Setting Lock Keyswitch Option***

Fitted on Priorclaves without program memory to give an optional level of security this keyswitch has two settings only, which are equivalent to positions 1 & 3 above. The key can only be removed in position 1.

### ***Load Sensed Process Timing***

#### **Load Sensed Process Timing Function**



If this option is fitted, the autoclave will be provided with an additional thermocouple. This is a PTFE coated stainless steel armoured probe that can be positioned in the load, ideally in the coolest part. When this option is selected, the autoclave will heat to the set chamber temperature as normal. However, when the set temperature is reached the process time will not begin to count down until the load temperature, as sensed by the additional thermocouple, reaches a temperature just below the set chamber temperature. The cycle will then proceed in the usual manner.

#### **Load Sensed Process Timing Purpose**

The use of load sensed process timing can greatly assist with the sterilisation of certain types of difficult dense loads, such as large baskets of bottle caps, pipette tips or animal feed, by ensuring that the load reaches set temperature. The system is also very effective for bagged plastic waste loads, however as these tend to melt down around the probe, consumption of probes can be high. For this type of use load validation may prove to be more successful and economical in the long term.

## **Positioning Load Sense Probe**

The probe should be positioned in what is anticipated to be the slowest part of the load to heat up, for example the centre of a large densely packed load, or the largest of a group of filled bottles. This is important, as there may be large variations in temperature distribution throughout the load.

**NOTE: Temperature variations can be reduced by the use of timed free steaming.**

## **Load Sense Thermocouples**

The load sensed process timing option utilises a thermocouple connected directly to the main processor board.

Replacement thermocouples are available from Priorclave.

See Maintenance - for details on thermocouple replacement.

## ***Printer***

The printer if fitted is mounted on the right hand side of the control panel. This provides a useful record of the cycle as well as an indication if any faults have occurred. The information printed is as follows:

*USER NAME (if provided at time of ordering)*

*DEPARTMENT (if provided at time of ordering)*

*AUTOCLAVE SERIAL NUMBER*

*DATE*

*CYCLE NUMBER*

*PROGRAM NUMBER (if multi-program memory option fitted)*

*TEMPERATURE AND TIME AT CYCLE START (time is set to G.M.T)*

*TEMPERATURE AND TIME AT END OF FREESTEAMING*

*TEMPERATURE AND TIME AT START OF PROCESS TIME*

The temperature and time are then recorded at pre-set time intervals, until the end of the process time.

*TEMPERATURE AND TIME AT END OF PROCESS TIME*

*TEMPERATURE AND TIME AT CYCLE COMPLETE.*

*CYCLE PASS/FAIL/ABORT*

(Fail means that a fault signal has occurred during the cycle or that the cycle was aborted. See - Warning Indicators)

The above information will be printed in the order listed, allowing the information to be read as it is printed.

At any time pressing the left-hand button on the lower right hand side of the printer can advance the paper.

## **REPLACING PRINTER PAPER ROLL**

Open the front of the printer by pushing the release catch on the far right of the printer unit to the left. The front of the printer unit will now swing open. The empty roll can now be pulled from the spindle, and the new roll fitted in its place. The end of the roll should then be fed into the slot at the top of the printer mechanism as shown in the diagram.

Place the end of the paper roll into the entry slot. It may help to tear the corners off the end of the roll to form an inverted V shape. Next, press the paper feed key on the front of the door (to the left of the release catch) and the paper will be drawn through the printer head.

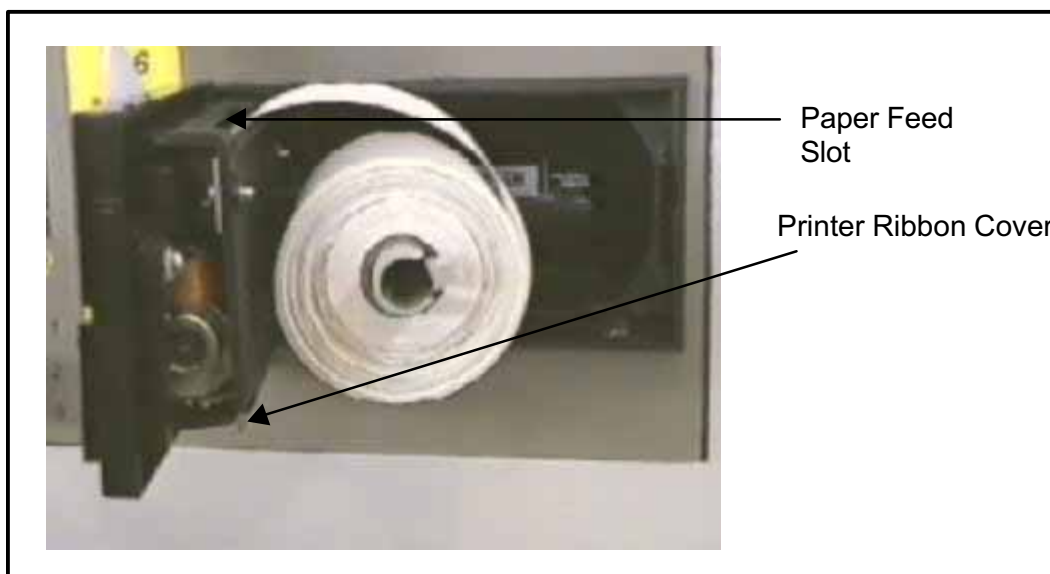

### **Replacing The Printer Ribbon Cassette**

When the printing becomes faint the ribbon cassette will need to be replaced. To do this, open the door and withdraw the end of the paper from the print mechanism. Next hold onto the front of the printer door with one hand and with the other gently squeeze together the top and bottom of the printer mechanism cover. Then gently lift the cover while holding the door in place. The cover and the outside of the door should now separate giving access to the printer ribbon cassette. The used cassette can then be removed by pulling up evenly from both ends of the cassette. Before fitting the new cassette take up any slack in the ribbon by rotating the take up wheel in the direction indicated on the cassette. The cassette can then be clipped into place. Any further slack that has developed should now be taken up. Push the two parts of the door together ensuring that they are securely joined and re-fit the printer roll. With the paper re-threaded and the door closed the printer is ready for use.

### **Chart Recorder**

If fitted, the recorder power input is connected directly to the autoclave in such a way that the recorder will only operate during the autoclave cycle, i.e. from the pressing of the start button to cycle complete. At this time power to the recorder is cut. Unless otherwise specified, single channel units record the temperature of a fixed thermocouple probe, and in the case of two channel units the second channel records the temperature of the load probe.

For more details on individual recorder function and operation please refer to the manufacturer's manual supplied with the autoclave.

### **Internal Validation System**

If fitted this system continuously monitors the performance of the temperature reading and control system with reference to an internal reference standard. If any problem is detected with the system the autoclave is stopped and a fault is signalled. (See Warning Indicators and Fault Codes for details.)

### **Air Intake Filter**

When fitted to the autoclave this system ensures that air drawn into the autoclave during the cooling stage of the cycle is first passed through a bacteriological air filter. This filter is fitted at the back of the autoclave.

## Vent Filter

When fitted to the autoclave this system passes all autoclave discharge through a filter fitted inside a pressurisable stainless steel housing. At the end of the cycle any unfiltered condensate from the filter housing is returned to the autoclave. The correct operation and effectiveness of the filter system should be regularly checked. Please refer to the manufacturers instructions enclosed with this manual.

## VACUUM OPTIONS

**N.B. It is strongly recommended that to achieve optimum performance from Priorclaves fitted with vacuum options that commissioning and/or load validation tests are carried out by a trained Priorclave engineer. If no particular programs have been specified your autoclave will be factory set with the following programs:**

**Program 1: Non vacuum Cycle**

**Program 2: Pre-Cycle Vacuum and Vacuum Cooling**

**Program 3: Pre-Cycle Vacuum and Vacuum Drying (if specified)**



### ***Pre-Cycle Vacuum***

The pre-cycle vacuum is selected using the lower function select key on the control panel. With the left-hand upper indicator lit the Pre-Cycle Vacuum is selected. With the Pre-Cycle Vacuum selected a vacuum pump will run at the beginning of the cycle, removing much of the air from the autoclave and load. At a pre-set level of vacuum the control system switches off the pump and the normal cycle begins. If set at commissioning a number of vacuum stages will be performed, with heating stages in between. Pre cycle vacuum is essential when autoclaving loads containing densely packed porous material.



### ***Drying Cycle - Suitable for Non Media Loads Only***

A drying cycle can be selected by means of the lower function select key. With the option selected the lower left-hand lamp will illuminate. When this option is fitted it can be run along with or separately from a Pre-Cycle Vacuum. With the option selected, at the end of the process dwell time the water charge is drained under pressure from the autoclave, and the autoclave cools to a pre-set temperature. If cooling has been selected the fan will operate at this stage. When this temperature is reached the fan switches off, a partial vacuum is drawn and heater mats attached to the outside of the vessel are switched on. This has the effect of evaporating liquid on the load. After a pre-set time air is admitted to the vessel and this process is repeated a number of times. At the end of this stage the autoclave passes immediately to cycle complete.

**Note: Post cycle drying must not be selected if the load contains bottled liquids, regardless of how these are contained. All liquids in the load will be evaporated. Sealed containers of liquid will explode. Unexploded containers will be in a dangerously unstable condition when removed.**



### ***Vacuum Cooling - Suitable for Non Media Loads Only***

**If fitted along with Vacuum Drying this option must be selected for attachment to a particular program in the control software during commissioning.**

A vacuum cooling cycle can be selected by means of the lower function select key. With the option selected the lower left-hand lamp will illuminate. When this option is fitted it can be run along with or separately from a Pre-Cycle Vacuum. With the option selected, at the end of the process dwell time autoclave vent is opened, and the autoclave cools to a pre-set temperature. If cooling has been selected the fan will operate at this stage. When this temperature is reached the fan continues to run and a partial vacuum is drawn. This has

the effect of evaporating liquid on the load causing it to cool rapidly. After a pre-set time air is admitted to the vessel and this process is repeated a number of times. At the end of this stage the autoclave passes immediately to cycle complete.

**Note: Post cycle vacuum cooling must not be selected if the load contains bottled liquids, regardless of how these are contained. All liquids in the load will be evaporated. Sealed containers of liquid will explode. Unexploded containers will be in a dangerously unstable condition when removed.**

## **Warning Indicators and Fault Codes**

On the control panel there are a series of 'hidden until active' warning indicators. Some of these indicators will appear in conjunction with a fault code in the temperature display. The meaning of these warnings, why they appear, and what to do when they appear, is as follows.

### **SERVICE**

This means that 500 cycles, or six months have passed since the autoclave was last serviced. The engineer will cancel the message when the autoclave is serviced.

### **WATER + FAULT CODE F004**

The water level has fallen below the minimum level and must be topped up before the autoclave can be run. The warning will automatically cancel when the door is opened and the water level is topped up. The low water condition may have caused a running cycle to abort, and the load may need to be autoclaved again.

### **O/HEAT + FAULT CODE F003**

If fitted, the heater over-temperature protection thermocouple may have sensed that the heating element became too hot. This is probably due to a low water condition, which was not sensed by the low water probe. The water level and the condition of the probe (see Maintenance) should be checked before attempting to use the autoclave again.

If heater over protection is not fitted then the over heat cut out will only operate under extreme conditions, such as a failure of the temperature control system. The next attempt to run the autoclave should be closely observed and if problems persist contact Priorclave Service.

### **FAULT + FAULT CODES F000, F002, F005, F006, F007, F008, F009, F010 & F011**

The fault indicator illuminates under conditions that may invalidate the autoclaving process, and may result in the load requiring to be autoclaved again. The fault condition will be triggered by any of the following:

- F006** Power to the autoclave being interrupted when a cycle is in the heating or process dwell stage of the cycle.
- F005** The chamber temperature falling below the set temperature by more than 3°C during the process dwell time.
- F002** Failure of the temperature control, display, or load simulator thermocouple.
- F000** If your autoclave is fitted with the optional self-validation system, an error in the temperature measurement system is signalled by fault code **F000**. Usually this would mean that a critical error has developed in the temperature measurement system, however, as the detection system is extremely sensitive it is possible that it may be triggered by fluctuations in the electrical power supply. If fault code **F000** appears it may be cleared by the method described below. If the fault code will not clear, or continues to re-appear then the user cannot correct the fault. In such a case please contact Priorclave service or your local Priorclave approved service agent.
- F007** Vacuum stage timeout (loop break). The autoclave has not achieved the pre-set level of vacuum during the Pre-cycle vacuum stage during the pre-set time.
- F008** Heating stage timeout. The autoclave has not reached process temperature within the Pre-set time.
- F009** Vacuum cooling set-point not achieved. The autoclave has not achieved a low enough level of vacuum during the post cycle vacuum stage (Vacuum Cooling or Drying Cycle)
- F010** Air detector input activated. If fitted the air detector system has detected an over pressure condition symptomatic of excess air remaining in the load.
- F011** Printer Timeout / Malfunction. The control system has not received confirmation from the printer within its pre-set timeout.
- F012** Door micro-switch fault. If a door micro-switch opens during a cycle this fault code is displayed

- F013** Jacket Timeout -If a jacket is fitted it has not reached the required temperature within the Pre-set time. This would indicate a problem with steam supply or inlet or drain valve operation
- F014** Jacket Over temperature - If a jacket is fitted the temperature has exceeded the pre-set alarm temperature
- F015** Jacket under temperature - If a jacket is fitted the temperature has fallen below the pre-set operating temperature band.
- F016** Water Fill Timeout - The upper level water probe level has not been reached within the allowed time for filling and the filling operation has been stopped. This function prevents continuous unsupervised operation of the water fill, which could lead to flooding.
- F017** FreeSteam - During Pulsed Fresteaming operation the lower of the two set temperatures has not been achieved. The temperature has not fallen sufficiently following the opening of the vent valve.

### **LOCK**

This warning will light when the thermal lock keyswitch is in the override position.

### **LOAD + FAULT CODE F001**

This warning is activated in the event of the failure of the load sensing thermocouple. If the autoclave is fitted with load sensed process timing, this should be deselected to enable the autoclave to run without this feature. The thermocouple should be replaced as soon as possible. Great care should be taken to ensure that loads which would ordinarily be autoclaved with load sensed process timing are adequately sterilised.

### **CANCELLING FAULT MESSAGES**

The fault messages are cancelled by first correcting the source of the original fault, then turning the setting lock key switch to position 3. If a key-switch is not fitted they are cancelled by pressing the reset button.

If 2 or more faults occur at the same time, the one with the highest priority is displayed. (F000 is the highest priority and F012 is the lowest.) If a higher priority fault is cleared it will be replaced by the next active fault, unless this too is cleared by the same action.

# MAINTENANCE

**NOTE:** Before carrying out any maintenance work check the autoclave for any visual signs of materials which may be contaminated or damaged. Should any such matter be apparent contact the relevant person of authority before proceeding.

Do not carry out any work unless you are competent to do so. Items in this section marked with \* are those which require a level of competence as incorrect maintenance or fitting could lead to a safety hazard.

**DISCONNECT** or **ISOLATE** the machine from mains power supply and steam supply before removing any panels or commencing any maintenance work.

**Ensure that any electrically locked doors are open before disconnecting power.**

**IN THE EVENT OF ANY DIFFICULTY** or doubt about any maintenance or service procedure contact Priorclave Limited or your nearest Priorclave approved agent or supplier immediately.

## **Weekly Maintenance**

- **Vessel Cleaning**

Check exterior of machine and the inside walls of the pressure vessel for general cleanliness, particularly around operating parts and switchgear. Under no circumstances should an abrasive or chemically aggressive cleaner be used on the pressure vessel. The use of chlorine or hydroxide based cleaners is not recommended (see notices at the beginning of this manual).

- **Gasket**

To prolong the life of the sealing gasket it is advisable to lubricate the sealing faces. This is carried out with the pressure lid in the open position by applying high melting point grease to the exposed surfaces of the gasket, after cleaning the gasket and inspecting for damage. A silicone grease such as high vacuum grease is ideal for this purpose

- **Locking Arms**

To ensure a free action of the locking arms they should be kept lubricated with high melting point grease and free from dirt.

- **Safety Valve \***

The safety valve should be periodically checked for freedom of movement. This can be accessed by removing the large patch panel on the left-hand side of the autoclave. When

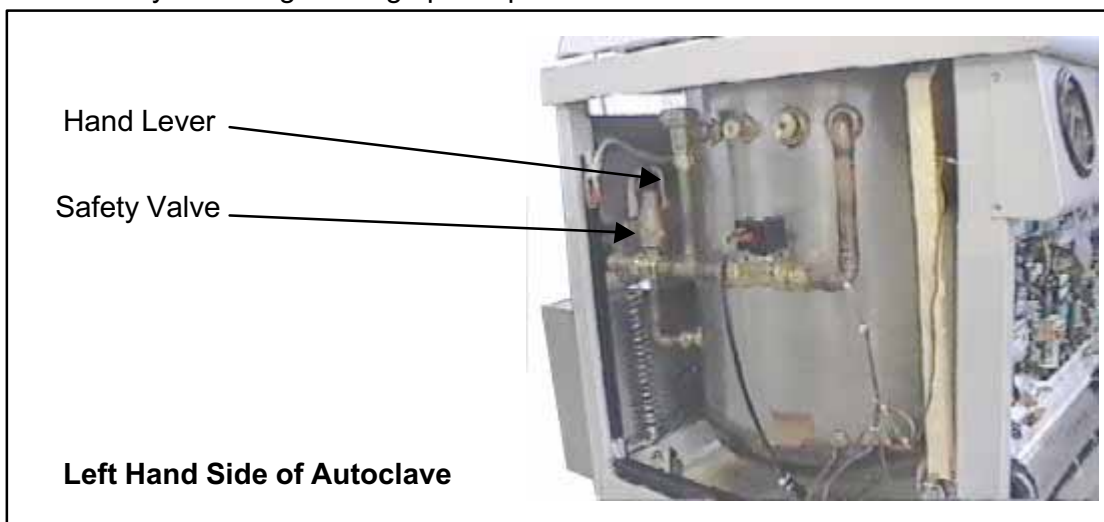

the autoclave is at working pressure, keeping well clear of the safety valve outlet, lift the hand lever and check for a free flow of steam from the outlet pipe. If steam does not flow



the valve should be replaced or serviced by a **qualified** person immediately. After releasing the lever ensure that the steam flow stops fully.

- **Drainage**

If the autoclave has been plumbed directly into a drain using flexible tubing, this should be checked for any signs of blockage, obstruction or damage. Also ensure that both ends of the tube are connected as originally intended. Check for any obstruction to the safety valve outlet, which must remain exposed and unconnected to any form of drainage at all times.

- **Steam Inlet Valve**

Check the condition, appearance and operation of the steam inlet solenoid valve at the back of the machine.

## ***Monthly Maintenance***

To be carried out in addition to weekly maintenance programme.

- **General Operation**

The general operation and performance of the autoclave should be observed frequently, and any fault or defect reported or rectified immediately, and entered into the notes section of the operating manual. (This will assist a service technician in locating any persistent fault and reporting it to the manufacturer.)

- **VACUUM PUMPS (If fitted)**

The operation of the vacuum pump(s) should be checked regularly. Please refer to enclosed vacuum pump manual for further details.

## ***Quarterly Maintenance***

- **HINGE \***

With the pressure lid in the open position the hinge should be cleaned and lubricated with high melting point grease.

- **AUTOMATIC AIR PURGE VALVE \***

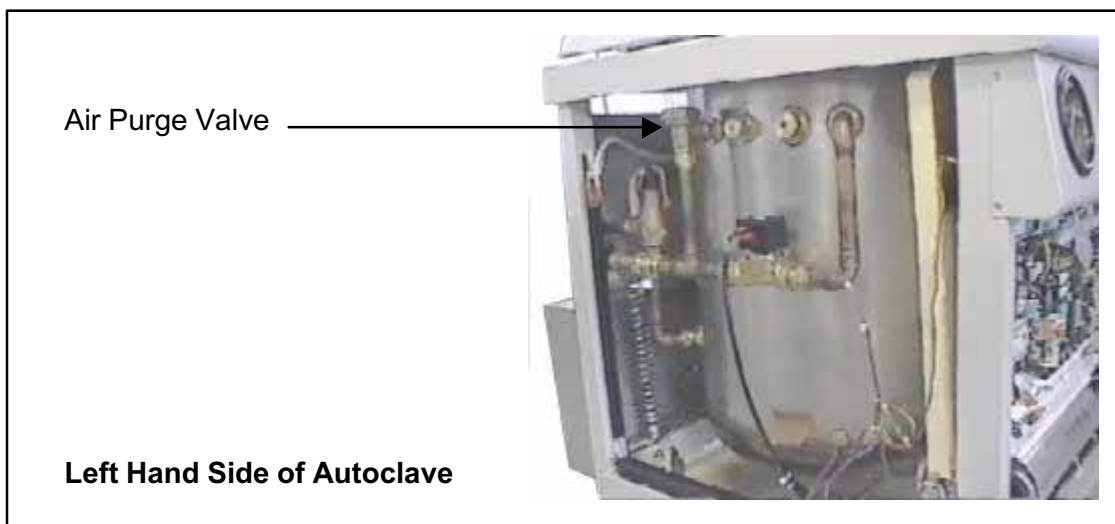

It is advisable to replace the expanding switching element and other sealing parts contained in this unit on a regular basis, in order to prevent build up of foreign matter which may impair the operation of the unit. The valve is situated on the left-hand side of the autoclave just below the header ring. To remove the parts for replacement simply unscrew the top cap of the unit and remove. Re-assemble the unit as per the instructions in the repair kit (available from PriorClave Limited or local agent). Should the top cap prove particularly tight the complete valve should be removed from the pressure vessel and the

body gripped in a vice to remove the cap, as excessive localised pressure could damage the pressure vessel. Care should be taken when refitting the valve to the pressure vessel that all gaskets etc., are replaced in the correct position and the unit should be checked for leaks when first re-pressurised.

- **STEAM TRAP AND STRAINER \***

The steam trap valve operates in the same way as the air purge valve described above but using an element rated at a different temperature. The valve and a strainer to protect it are mounted externally at the back of the autoclave. The strainer drain should be emptied periodically and the valve element serviced as described above.

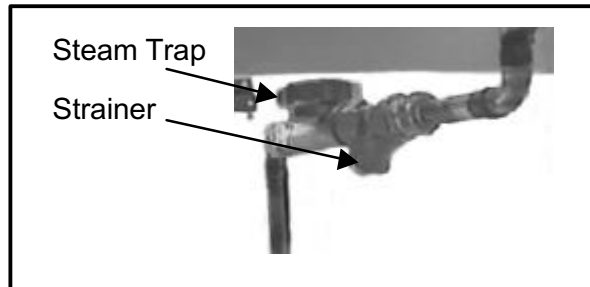

- **Microswitches \***

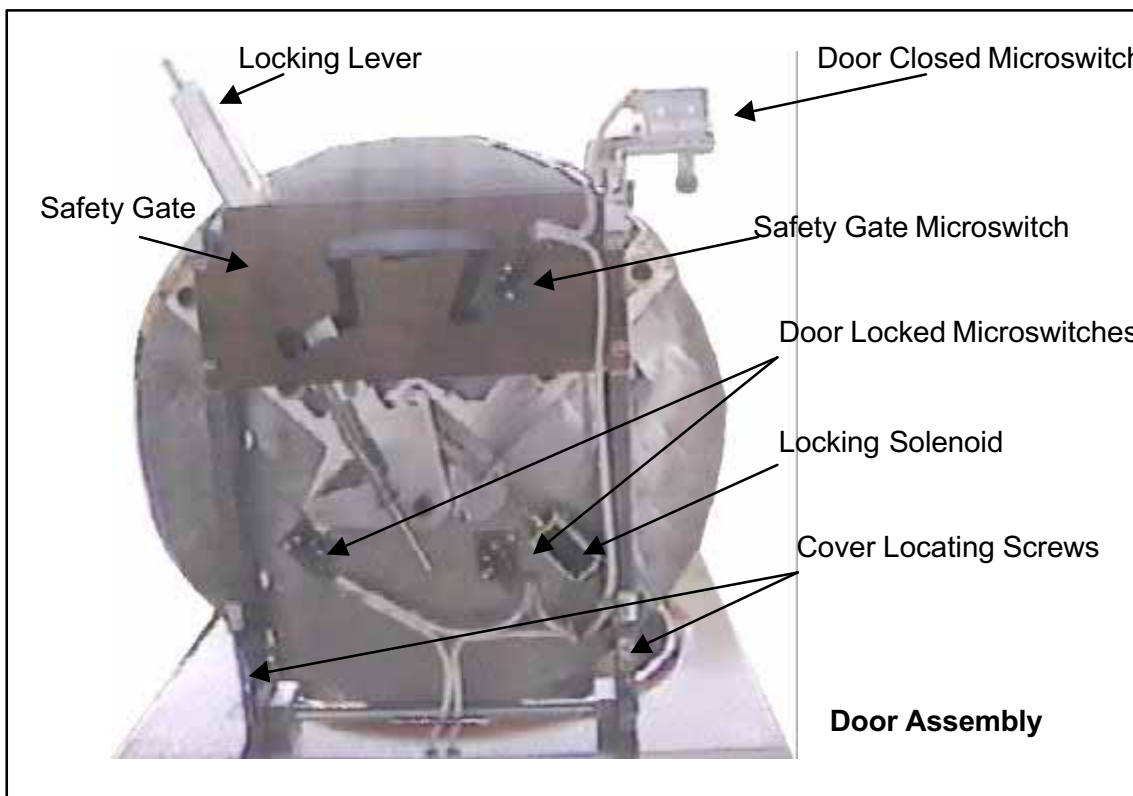

To ensure the reliable operation of the autoclave the internal microswitches, located on the lid located beneath the lid cover, should be regularly cleaned and checked.

To gain access to these switches first remove the top cover with the door open.

To remove the cover; first unscrew and remove the yellow locking handle. Next undo the two securing nuts. These are located behind the access slots at the inside top of the cover. Finally carefully pull the cover over the locking handle. Replacement of the cover is the reverse of the above procedure, but care should be taken that the slots in the back end of the cover are securely located onto the screws at the back of the door.

First check the condition and operation of the small microswitches on the safety gate and on the lid plate close to the locking solenoid. Next check the condition of the larger door closed microswitch. Then close the door and check the position in which it is operating the switch. If necessary, adjust the position of the switch until correct operation is achieved.

- **Locking Solenoid \***

With door cover removed, check the locking pin and solenoid for freedom of movement. If necessary the screws should be tightened and the solenoid re-aligned with the pin.



Door Closed Microswitch - Detail



Locking Solenoid & Microswitches - Detail

- **Filters (If fitted)**

The condition of air intake filters should be inspected regularly. These filters should be sterilised (they can be autoclaved) on a regular basis.

\* Outlet filters, where fitted should be regularly inspected, sterilised and replaced.

**Inadequate maintenance could cause a significant biohazard.** Please refer to the enclosed manual for the filter system for more details.

### **General Maintenance**

- **Removing Side Panels \***

To remove these panels simply remove the screws from the lower corner of each panel and pull the panel down (taking care it does not fall) until clear of the top panel.

- **Removing Front Panel \***

(Access to control components)

Remove the bottom front retaining screws on the autoclave legs at the front. With these screws removed, the front panel may now be pulled down and forwards.

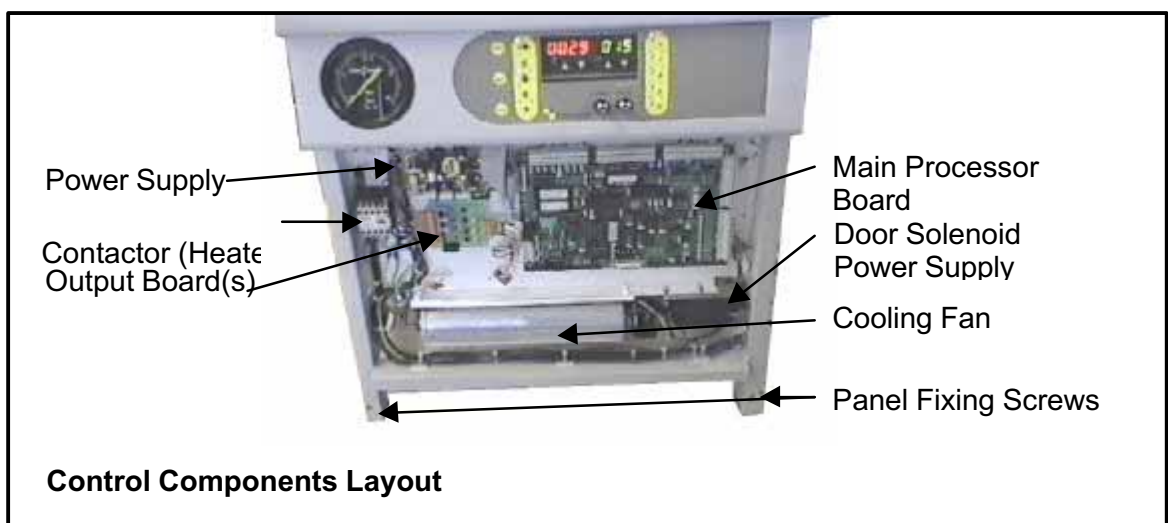

- **Checking Temperature Control And Pressure Gauge \***

Should a constant deviation from the values shown in the steam table (appendix B) be apparent in these instruments first follow the relevant procedures in the fault-finding table (appendix A). With all of these possible causes eliminated, proceed to check the gauges as follows:

First, place a thermocouple probe connected to a digital thermometer or chart recorder of known accuracy onto the Temperature Controller Probe. Then set the machine and run through a standard cycle. When the process time has commenced check the reading shown by the temperature display against that of the thermometer or recorder. Should there be a disparity of readings in the order of that previously noted then it is likely that the Temperature Controller is at fault and needs resetting.

If only negligible temperature disparity is apparent, however, and the steam pressure is still varying from the expected value by the amount noted previously, then the pressure gauge is probably faulty and in need of replacement.

**N.B. THE PRESSURE GAUGE AND CONTROL SYSTEM FITTED TO PRIORCLAVES ARE EXTREMELY RELIABLE INSTRUMENTS AND AS SUCH ARE UNLIKELY TO PRODUCE FALSE READINGS. THEREFORE IT IS MORE LIKELY THAT ANY DEVIATION FROM THE VALUES GIVEN IN THE STEAM TABLE IS CAUSED BY INCORRECT AIR PURGING ETC.**

- **Fitting A New Lid Gasket**

When it becomes necessary to replace the gasket, simply remove the old gasket by pulling it out of the groove in the pressure vessel body.

Using an abrasive pad clean out the groove and wipe away any residue with a cloth. Locate the joint in the new gasket and press this part of the gasket firmly into the part of the groove closest to the hinge, marked A on diagram C.

Find the opposite centre line of the gasket and press firmly into the point marked B on the diagram, ensure that there is an even amount of gasket each side of points A and B. Press the gasket into the points marked C, again ensuring that there is an even amount of gasket between all 4 points.

Press the gasket into the four points marked D. Finally press in the remaining points taking care not to cut the gasket on the header ring. Once the gasket is fully fitted smear the top surfaces with high temperature silicone grease if required, and smooth out any lumps, applying pressure in a circular motion around the gasket.

With the new gasket properly fitted, locking the lid may at first be a little tight. Please note however that the gasket will bed down considerably when the autoclave is first used.

- **Fitting A New Wandering Thermocouple**

The autoclave is fitted with two thermocouple entry ports located behind the large patch panel on the left-hand side of the autoclave. The large port is intended for multiple test probes for use during performance testing and the smaller port is intended for use with the wandering thermocouple used for Load Sensed Process Timing. To remove the

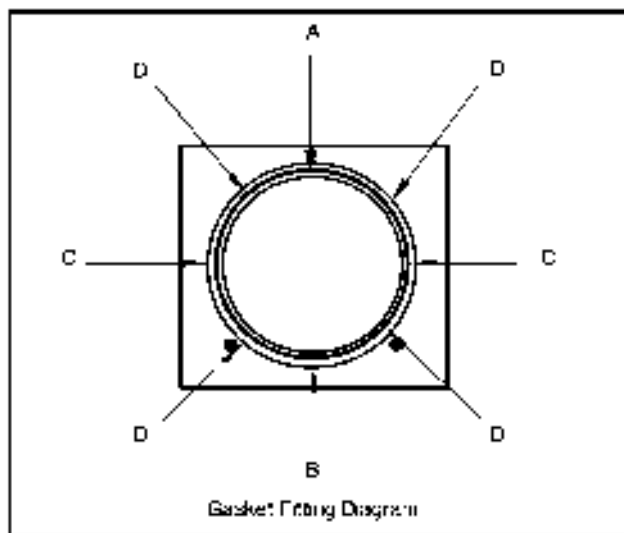
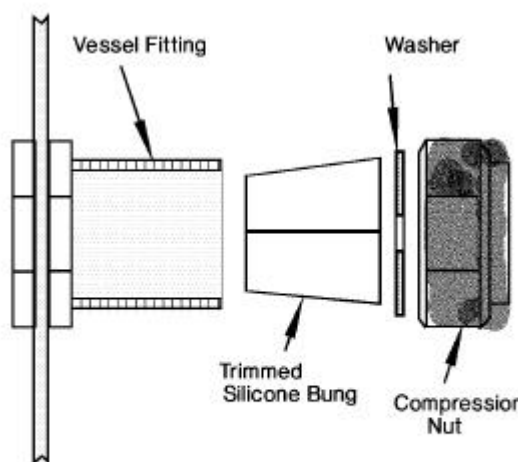
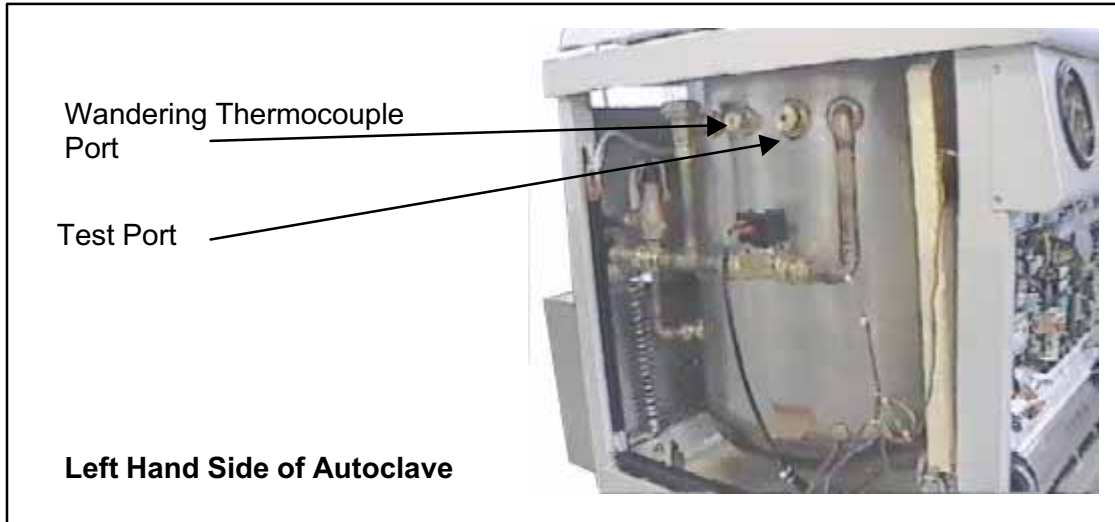

Diagram C



Entry Port Fitting - Detail

old thermocouple first unplug it from its connection to the main control board and then undo and remove the compression nut from the fitting (see diagram). Using a suitable blunt instrument, from the inside of the pressure vessel push out the silicone rubber bung from the fitting, and remove it from the thermocouple. Next, insert the new thermocouple, it may be necessary to re-slit the bung to do this. Place the nut washer and bung in position on the new thermocouple and re-fit. It is advisable to apply some silicone sealant (such as bath sealant) to the joint to assist sealing. The joint should be checked for leaks when the autoclave is first pressurised. Replacement bungs are available from Priorclave, or alternatively use a No. 21 (large port) or a No. 13 (small port) silicone rubber bung and trim the top end by about 5mm.



# SPARES LIST

A full selection of spares are available from Priorclave Service or your local Priorclave dealer. Please give your autoclave serial number when ordering parts.

A selection of the more commonly used parts is listed below:

DESCRIPTION	PART NUMBER	
Gasket	ACS/GAS/001	
Door Locking Solenoid	AQS/LSN/003	
Air Purge Valve Element	ACS/PVE/005	
Condensate Return Valve Element Kit (E)	ACS/PVT/063	
Condensate Return Valve	ACS/CRV/037	
Air Purge Valve (Complete)	ACS/PVC/037	
15mm (1/2") Solenoid Valve (Steam inlet)	MID/VVC/007	
Vent Valve Complete	ACS/VVC/007	

Safety Valve - Complete	ACS/SVC/008	
Pressure Gauge	ACS/PGA/009	
Thermal Lock Keyswitch	ACS/TLK/012	
Setting Lock Keyswitch	ACS/SLK/001	
Output Card	TAC/OPT/054	
Printer Paper Roll	TAC/ROL/053	
Printer Ribbon Cassette	TAC/RIB/152	
Door Lock Microswitch	ACS/MSS/025	
Door Closed Microswitch	AQS/MSS/000	



Wandering Thermocouple Probe	ACS/PRB/039	
Air Intake Filter	ACS/AFL/039	
Pressure Switch	MID/PSW/028	
Locking Clamp Shim	AQS/LCS/002	
Hinge Block Shim	AQS/HBS/001	
Single Pole Circuit Breaker 6A	ACS/MCB/001	
Small Cable Port Bung	ACS/SBG/015	
Large Cable Port Bung	ACS/SBG/022	



# Specification Tables

## Model PS/QCS/SV100

<b>General</b>	<b>Model</b>	Top Loading Priorclave
	<b>Capacity</b>	100 Litres
<b>Dimensions</b>	<b>Machine (wxd)</b>	660x800mm
	<b>Installation Area Required (wxd)</b>	660x940mm
<b>Weight</b>	<b>Unloaded</b>	195kG
	<b>Door</b>	50kG
	<b>Pressure Vessel</b>	30kG
<b>Electrical</b>	<b>Power Supply Required</b>	230V 50Hz 6A (may vary according to options fitted)
<b>Steam</b>	<b>Steam Supply Required</b>	Dry steam regulated to 40 psi
<b>Water Supply</b>	<b>Water Supply Required</b>	N/A
<b>Drainage</b>	<b>Main Drain Connection</b>	22mm BSP
	<b>Secondary Drain Connections</b>	Condensate Return - 15mm BSP Others -15mm BSP (if Applicable)
<b>Max. Sound Level</b>	<b>Without Vacuum Pump</b>	Approx. 30db @ 1M
	<b>With Vacuum Pump</b>	Approx. 75db @ 1M
<b>Max. Heat Emission</b>	<b>Full Cycle</b>	$((10.5h \times 5.25p) \times 0.75) / t$ kW/Hour Where: <b>h</b> = heat-up time (hrs) <b>p</b> = process time (hrs) <b>t</b> = Total cycle* (hrs) * to thermal lock temperature

**Model PS/QCS/SV150**

<b>General</b>	<b>Model</b>	Top Loading Priorclave
	<b>Capacity</b>	150 Litres
<b>Dimensions</b>	<b>Machine (wxd)</b>	660x800mm
	<b>Installation Area Required (wxd)</b>	660x940mm
<b>Weight</b>	<b>Unloaded</b>	215kG
	<b>Door</b>	50kG
	<b>Pressure Vessel</b>	32kG
<b>Electrical</b>	<b>Power Supply Required</b>	230V 50Hz 6A (may vary according to options fitted)
<b>Steam</b>	<b>Steam Supply Required</b>	Dry steam regulated to 40 psi
<b>Water Supply</b>	<b>Water Supply Required</b>	N/A
<b>Drainage</b>	<b>Main Drain Connection</b>	22mm BSP
	<b>Secondary Drain Connections</b>	Condensate Return - 15mm BSP Others -15mm BSP (if Applicable)
<b>Max. Sound Level</b>	<b>Without Vacuum Pump</b>	Approx. 30db @ 1M
	<b>With Vacuum Pump</b>	Approx. 75db @ 1M
<b>Max. Heat Emission</b>	<b>Full Cycle</b>	$((10.5h \times 5.25p) \times 0.75) / t$ kW/Hour Where: <b>h</b> = heat-up time (hrs) <b>p</b> = process time (hrs) <b>t</b> = Total cycle* (hrs) * to thermal lock temperature

# NOTES

## NOTES

## APPENDIX A - FAULT FINDING & RECTIFICATION GUIDE

SYMPTOM	POSSIBLE CAUSE	POSSIBLE SOLUTION
<b>No Power</b>	<ul style="list-style-type: none"> <li>• Power switched off at isolator</li> <li>• Circuit Breaker Tripped</li> <li>• Electrical Failure</li> </ul>	<ul style="list-style-type: none"> <li>• Check</li> <li>• Reset and check cause</li> <li>• Call Engineer</li> </ul>
<b>Cycle does not commence when start button is pressed (Fault indicator flashes)</b>	<ul style="list-style-type: none"> <li>• Door is not closed properly</li> <li>• Microswitch Failure</li> </ul>	<ul style="list-style-type: none"> <li>• Open &amp; Reclose. Check Locking Bolt Function</li> <li>• Check Microswitches</li> </ul>
<b>Heating slow or not apparent</b>	<ul style="list-style-type: none"> <li>• Controller incorrectly set</li> <li>• No steam supply, or inadequate steam pressure.</li> <li>• Inlet Valve Failure</li> <li>• Fault in control circuit.</li> </ul>	<ul style="list-style-type: none"> <li>• Check setting &amp; reset if necessary</li> <li>• Check Isolator valve is open.</li> <li>• Check reducing valve setting and operation.</li> <li>• Check supply pressure.</li> <li>• Check and replace if necessary.</li> <li>• Check all connections and output board function .</li> </ul>
<b>Autoclave does not pressurise</b>	<ul style="list-style-type: none"> <li>• Vent button in open position</li> <li>• Freesteam time not completed (if option is fitted)</li> <li>• Air purge valve failure</li> <li>• Vent Valve stuck open</li> <li>• Safety Valve stuck open</li> <li>• Door incorrectly closed</li> </ul>	<ul style="list-style-type: none"> <li>• Check Vent Indicator</li> <li>• Check Cycle Progress Indicator Display</li> <li>• Check and replace internal parts or valve.</li> <li>• Check &amp; Replace if necessary</li> <li>• Check for obstructions on lifting handle.</li> <li>• Check door position and microswitch settings</li> </ul>
<b>Incorrect Temperature/Pressure Correlation</b>	<ul style="list-style-type: none"> <li>• Air not fully purged from autoclave. Due to :</li> <li>• Incorrect Load Packing</li> <li>• Faulty Air Purge Valve</li> <li>• Faulty Controller or Gauge</li> </ul>	<ul style="list-style-type: none"> <li>• Re-Load and re-start cycle with (more) freesteam.</li> <li>• Check &amp; Replace if necessary</li> <li>• Check function and calibration</li> </ul>

SYMPTOM	POSSIBLE CAUSE	POSSIBLE SOLUTION
<b>Safety Valve opening</b>	<ul style="list-style-type: none"> <li>• Temperature set too high</li> <li>• Output board Failure</li> <li>• Safety Valve Faulty</li> </ul>	<ul style="list-style-type: none"> <li>• Check Temperature Setting</li> <li>• Check &amp; Replace if necessary.</li> <li>• Check the lock on the valve is intact and has not been tampered with and that the lifting handle is not obstructed. Check the pressure shown on the gauge is above 2.2 Bar. If not replace the valve.</li> </ul>
<b>Door will not open once Autoclave has cooled to 80°C</b>	<ul style="list-style-type: none"> <li>• Thermal Lock Temperature not yet reached in Load Simulator</li> </ul>	<ul style="list-style-type: none"> <li>• <b>WAIT.</b> Thermal Lock is set to Load and not Chamber temperature.</li> </ul>
<b>Door does not open when door button is pressed</b>	<ul style="list-style-type: none"> <li>• Safety delay not completed</li> <li>• Thermal Lock Temperature not yet reached in load simulator</li> <li>• Faulty Door Solenoid(s)</li> <li>• Thermal Lock previously overridden</li> </ul>	<ul style="list-style-type: none"> <li>• Wait while '<b>hoLd</b>' is displayed in the temperature display</li> <li>• Check Cycle Complete indicator is lit on cycle progress display.</li> <li>• Check Solenoid and Output Board Function. Replace if necessary.</li> <li>• Use thermal lock key to open door. Normal function will return after a complete cycle has been run.</li> </ul>
<b>Fault Indication will not go out</b>	<ul style="list-style-type: none"> <li>• Fault not Re-set. (Refer to manual for list of Fault Codes)</li> </ul>	<ul style="list-style-type: none"> <li>• Rectify cause of fault and reset with Keyswitch or re-set button.</li> </ul>

If in any doubt about any of the above procedures do not hesitate to call Priorclave Service on **020 8316 6620** or your nearest Priorclave approved service agent.

## APPENDIX B - STEAM TABLE

Temperature (°C)	Pressure (Bar)
100	0.00
105	0.20
110	0.43
115	0.69
120	0.99
121	1.06
122	1.13
124	1.26
126	1.41
128	1.56
130	1.72
132	1.89
134	2.07
136	2.20

**Correct Correlation between Temperature and Pressure shows correct operation of the autoclave and that air purging is satisfactory.**

**NB.**

This table is accurate at sea level and at moderate altitudes will be sufficiently accurate for its intended purpose. However, at higher altitudes the pressures indicated will be slightly higher than those shown above





# APPENDIX C - WIRING DIAGRAMS

## Output Board Designations

### Output Board 1

IN		OUT	FUNCTION
	<b>1</b>		
	<b>2</b>		
	<b>3</b>		
	<b>4</b>		

### Output Board 2

IN		OUT	FUNCTION
	<b>1</b>		
	<b>2</b>		
	<b>3</b>		
	<b>4</b>		



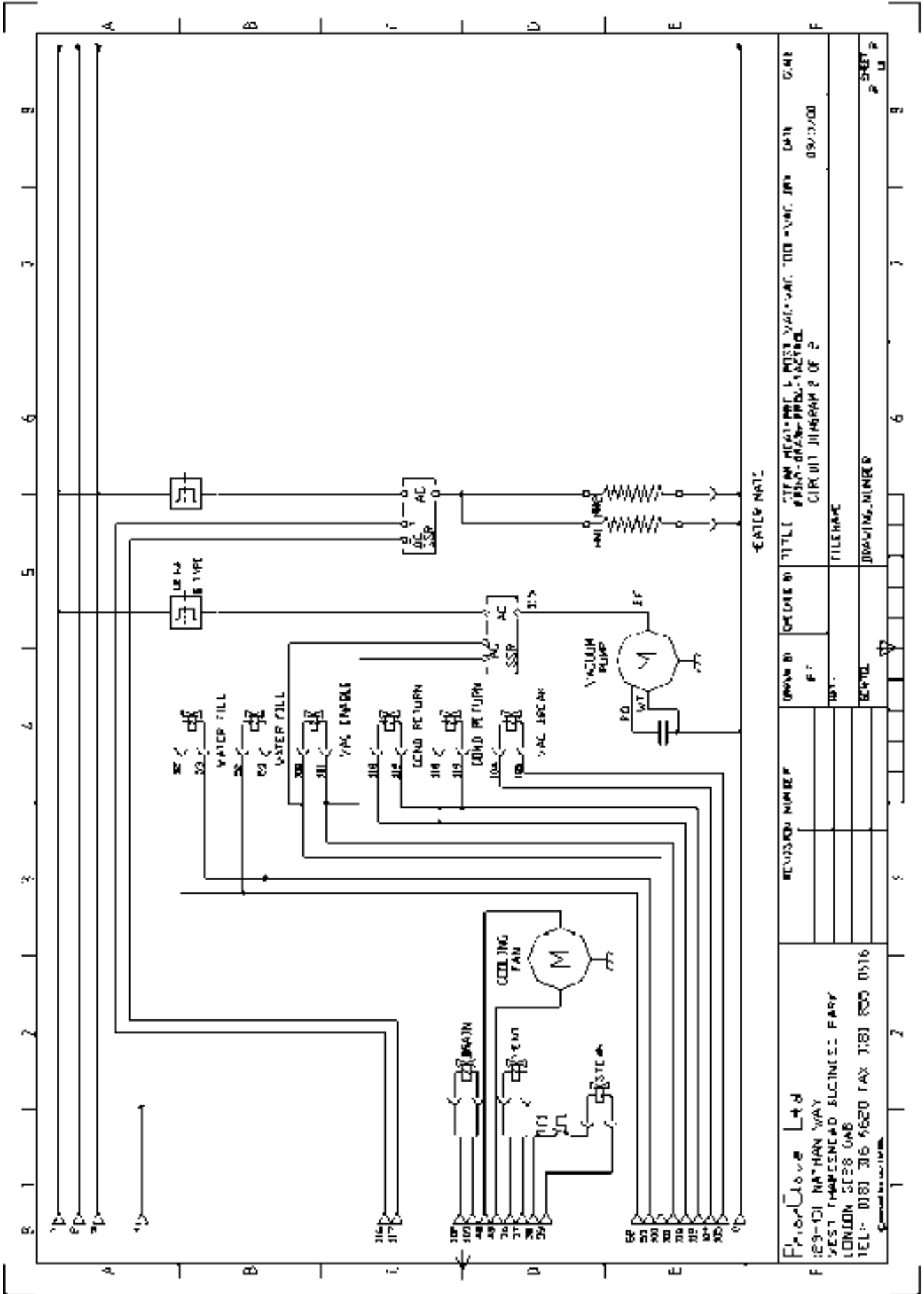

<b>PriorClave Ltd</b> 1259-131 NATHAN WAY WEST PHARMACEUTICAL BUSINESS PARK LONDON SE26 0AB TEL: 0181 316 6620 FAX: 0181 800 0516 <small>Copyright © 1998 PriorClave Ltd</small>		REVISION NUMBER 1 2 3 4 5 6 7 8 9	DRAWN BY F: DESIGNED BY BEATLEY	TITLE CIPM HEAT-ME 1, PMSI VAC-VAC, TO VAC. JPN PRINT-DRAW-PROG-FACTORY CIRCUIT DIAGRAM 2 OF 2	FILE NAME DRAWING NUMBER 2 SHEET 2 3 4 5 6 7 8 9
---	--	--	--	---	---

# PIPEWORK SCHEMATIC

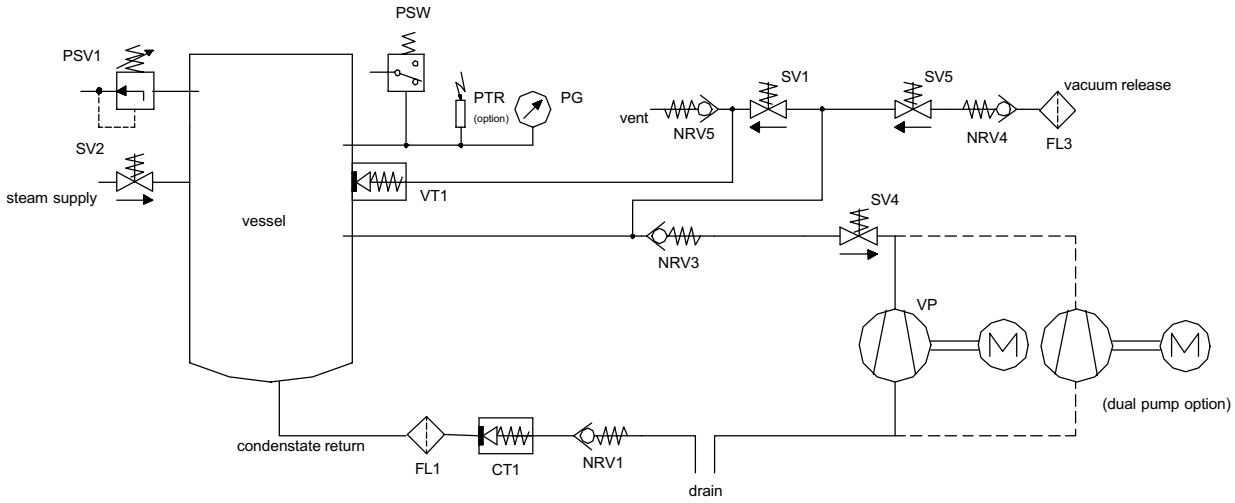

## STEAM HEATED WITH DIAPHRAM VACUUM PUMP

file:steam heated with diaphragm pump.dwg

issue: A date: 28/03/00 drawn: JC

## **APPENDIX D - OTHER OPTIONS FITTED**



## Opening Instructions

Your Priorclave Autoclave is electrically locked. In order to open it and access the full operating instructions it will first be necessary to connect it to a suitable electrical supply as follows:



To connect your Priorclave to the power supply simply connect a suitable cable from your isolator to the isolator at the rear of the unit. Wiring for single and three phase supplies is as shown in the diagrams.

Your Priorclave can be wired in one of two electrical configurations depending on the power supply available. If in doubt as to which one applies check your power supply.

### • 7 kW SINGLE PHASE

The power supply to the Autoclave should be run from a suitable 30 Amp isolator or a 13A power socket (see specification sheet) and connected to the isolator as below. Sufficient length of cable should be used to allow the autoclave to be pulled out and worked on from the back. The earth, live and neutral feeds should all be capable of carrying 30 Amps. The neutral line must be nominally at earth potential, must not be fused and the equipment must be earthed.

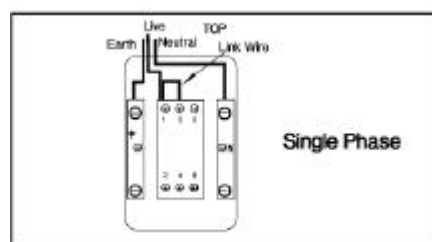

### • 3 PHASE – Liquid Ring Vacuum Pumps

The power supply should be a 3 phase and neutral isolated supply, rated at 15 Amps per phase, connected to the isolator. Sufficient length of cable should be used to allow the autoclave to be pulled out and worked on from the back. The cable used to the earth line and neutral feeds should be capable of carrying the per phase amperage of the supply. The neutral line must be nominally at earth potential and must **NOT** be fused. This equipment must be earthed.

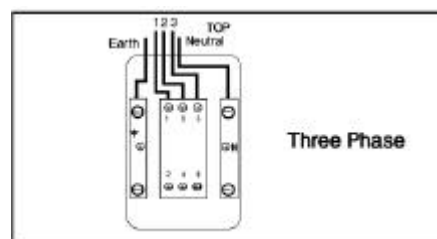

After connecting the autoclave to a suitable power supply it can be opened as follows:

1. Check that the power is **ON** at the wall isolator.
2. Switch on the power at the isolator at the back of the autoclave (for position see diagrams above). All indicators will light momentarily and a sounder will bleep. This enables the indicators to be checked. The **low water** indicator should now be lit.
3. Press and release the **door** button, which will bleep, and wait for a short time (about 20 seconds) until the **door** indicator illuminates and the sounder bleeps again. On pressing the **door** button a second time, you will hear the locking bolt withdraw.
4. Open the autoclave door as described below:
  - g) Move the locking handle to the right
  - h) The handle will now spring out into its unlocking position
  - i) Move the handle fully to the right to unlock the door. The handle is now in its safety lock position, allowing any residue of pressure inside the autoclave to escape harmlessly.
  - j) Move the handle slightly to the right to release it from the safety position
  - k) Push the handle in as far as it will go
  - l) Move the handle fully to the right to its parked position

