

Fitting a New Lid Gasket – Rectangular Vessel Machines

When it becomes necessary to replace the gasket, simply remove the old gasket by pulling it out of the groove in the pressure vessel body.

Use a lightly abrasive pad to clean out the gasket groove. Wipe away any residue or debris with a cloth.

Locate the joint in the new gasket.

Hold the gasket approximately 50mm each side of the joint and gently press the gasket into the newly cleaned groove at its first mounting position, **A** on the diagram below ensuring that there is NO stretch or tension along the length of the gasket at this first mounting position.

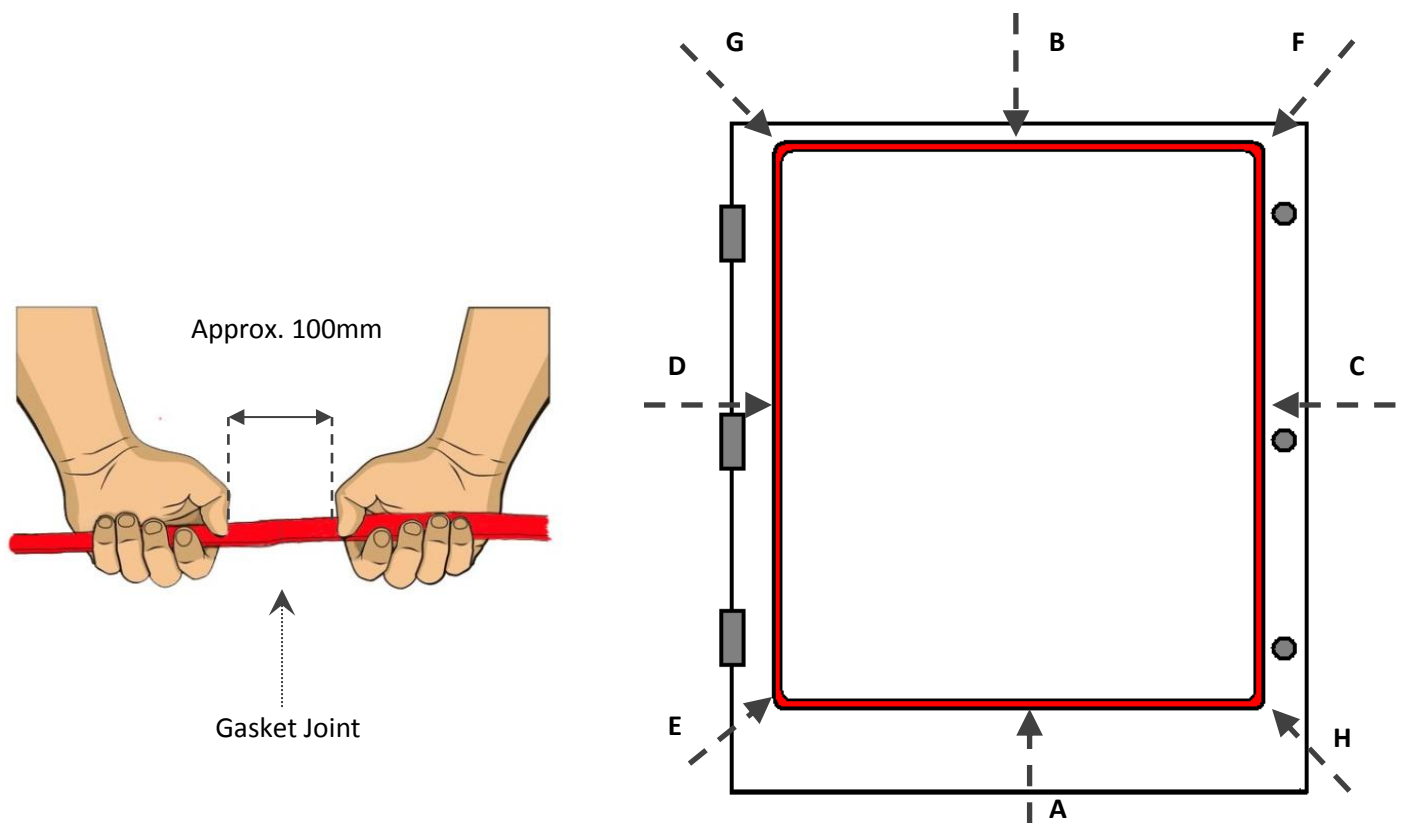

Find the opposite centre line of the gasket and press firmly into the point marked **B** on the diagram, ensure that there is an even amount of gasket each side of points **A** and **B**.

Press the gasket into the points marked **C**, again ensuring that there is an even amount of gasket between all 4 points.

Press the gasket into the four points marked **D**. Finally press in the remaining points, E through to H. Use a rubber mallet to gently tap in the seal evenly along the line of the gasket groove smoothing out any lumps using a rubber mallet.

Once the gasket is fully seated, smear the top surfaces with high temperature silicone grease if required, With the new gasket properly fitted, locking the lid may at first be a little tight. Please note however that the gasket will bed down considerably when the autoclave is first used (during the first heat cycles)