



100L AUTOCLAVE TOP LOADING

EV100-BASE
SV100-BASE



150L AUTOCLAVE TOP LOADING

EV150-BASE
SV150-BASE



200L AUTOCLAVE TOP LOADING

EV200-BASE
SV200-BASE

Priorclave's Base range covers "the basics": media preparation, waste loads, and sterilising loose instruments, open containers, and labware. Top-loading autoclaves are among our best-sellers worldwide, owing to their high efficiency and small footprint (relative to chamber size). They are especially sought after by research, quality assurance, and teaching labs that must regularly process taller flasks, fermentors, or bioreactors. Base models include fully programmable cycle customisation, "media warming," integrated cooling and freesteaming systems, and drain protection. Easy maintenance and light resource consumption help ensure a low lifetime cost of ownership.

SPEAK WITH AN AUTOCLAVE EXPERT



+44 (0)20 8316 6620 • priorclave.co.uk • sales@priorclave.co.uk

Our highly trained service technicians provide dedicated pre- and after-sales support including planned maintenance programmes to ensure you get the most from your Priorclave.

KEY FEATURES

- Quickseal single-action door fitted with thermal and pressure locks to prevent opening at load temperature above 80°C and pressures above 0.2 bar.
- Tactrol® 3 microprocessor control with simple and fully variable setting of process time, temperature with graphic indication of cycle status.
- Automatic timed free-steaming.
- Forced Air Cooling.
- Epoxy coated panels and frame members are treated with an anti-bacterial agent which is effective against all bacteria and fungi including MRSA.
- Media Warming and Delayed Start functions keep autoclaved media at a usable temperature ready for immediate use.
- Supplied with two (100L) or three (150L) stainless baskets.
- Pressure vessel carries a 10 year warranty and is insurance approved.
- Service and support direct from manufacturer (or appointed distributor).

100L AUTOCLAVE TOP LOADING

EV100-BASE, SV100-BASE

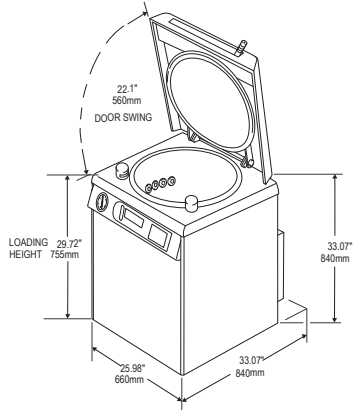

Heat Input	Chamber Volume	Operating Range	Loading Format	Loading Height	Heating Power
Electrical or Direct Steam Source	100 Liters	Up to 138 °C, 2.4 Bar (280 °F 34 psi)	Top Loading	755mm (29.72")	7kW - 30A single-phase 10.5kW - 15A three-phase
Chamber Dimensions diameter x depth		Bottom Shelf Dimensions w x d		Top Shelf Dimensions w x d	
500 x 500mm (19.68" x 19.68")		n/a		n/a	
Outside Dimensions w x d x h	Weight (unloaded)	Minimum Installation w x d		Door Swing	
660 x 840 x 840mm (25.98" x 33.07" x 33.07")	157kg (346.12 lbs)	980 x 1400mm (38.58" x 55.11") (including Door Swing)		560mm (22.1")	

150L AUTOCLAVE TOP LOADING

EV150-BASE, SV150-BASE

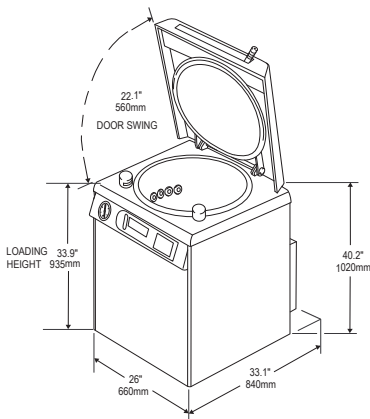

Heat Input	Chamber Volume	Operating Range	Loading Format	Loading Height	Heating Power
Electrical or Direct Steam Source	150 Liters	Up to 138 °C, 2.4 Bar (280 °F 34 psi)	Top Loading	935mm (33.9")	7kW - 30A single-phase 10.5kW - 15A three-phase
Chamber Dimensions diameter x depth		Bottom Shelf Dimensions w x d		Top Shelf Dimensions w x d	
500 x 720mm (19.5" x 28.4")		n/a		n/a	
Outside Dimensions w x d x h	Weight (unloaded)	Minimum Installation w x d		Door Swing	
660 x 840 x 1020mm (26" x 33.1" x 40.2")	175kg (363.76 lbs)	980 x 1600mm (38.58" x 62.99") (including Door swing)		560mm (22.1")	

200L AUTOCLAVE TOP LOADING

EV200-BASE, SV200-BASE

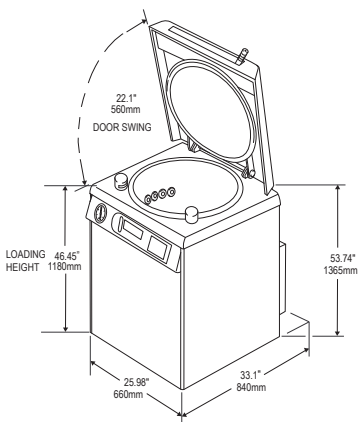

Heat Input	Chamber Volume	Operating Range	Loading Format	Loading Height	Heating Power
Electrical or Direct Steam Source	200 litres	Up to 138 °C, 2.4 Bar (280 °F 34 psi)	Top Loading	1180mm (46.45")	7kW - 30A single-phase 10.5kW - 15A three-phase
Chamber Dimensions diameter x depth		Bottom Shelf Dimensions w x d		Top Shelf Dimensions w x d	
500 x 1000mm (19.5" x 39.37")		n/a		n/a	
Outside Dimensions w x d x h	Weight (unloaded)	Minimum Installation w x d		Door Swing	
660 x 840 x 1365mm (25.98" x 33.1" x 53.74")	185kg (407.85 lbs)	980 x 1925mm (38.58" x 75.78") (including door swing)		560mm (22.1")	

CONFORMITY & COMPLIANCE

UK Standard	ISO 9001 / CE Marked / BS2646
US Standard	ASME
EU Standard	CE / ISO 9001 / PED 97/23/EC

INT Standard	EMC Compliance
Sustainability	ACT Label Issued
Service	Priorclave Trained Standard